

Ice-O-Matic[®]

SERVICE PARTS MANUAL 22 INCH WIDE ICE SERIES CUBERS MODEL-ICE0320, ICE0520

Includes 50Hz. Units



ICE-O-Matic
11100 East 45th Ave
Denver, Colorado 80239

Part Number 9081297-01

Rev 6/06

ICE0320/0520 Service Parts

This parts list contains the service parts available for the ICE0320/0520 icemakers.

Check the model number on the data plate and refer to the correct listing for the specific component.

Check carefully that the correct part is identified and ordered.

Table of Contents	Page 1
Cabinet Exterior	Page 2
ICE0320 Air Cooled	Page 3
ICE0520 Air Cooled	Page 4
Water Cooled	Page 5
ICE0320 Evaporator	Page 6
ICE0520 Evaporator	Page 7
ICE0320 Air Condenser Components	Page 8
ICE0520 Air Condenser Components	Page 9
Water Cooled Condenser Components	Page 10
Water Pump/Float	Page 11
Control Box	Page 12
Old Style Harvest Assist Assembly	Page 13
New Style Harvest Assist Assembly	Page 14 - 15
Specific Compressor Components	Page 16

ICE-O-Matic
11100 East 45th Ave.
Denver Co. 80239
866 PUREICE

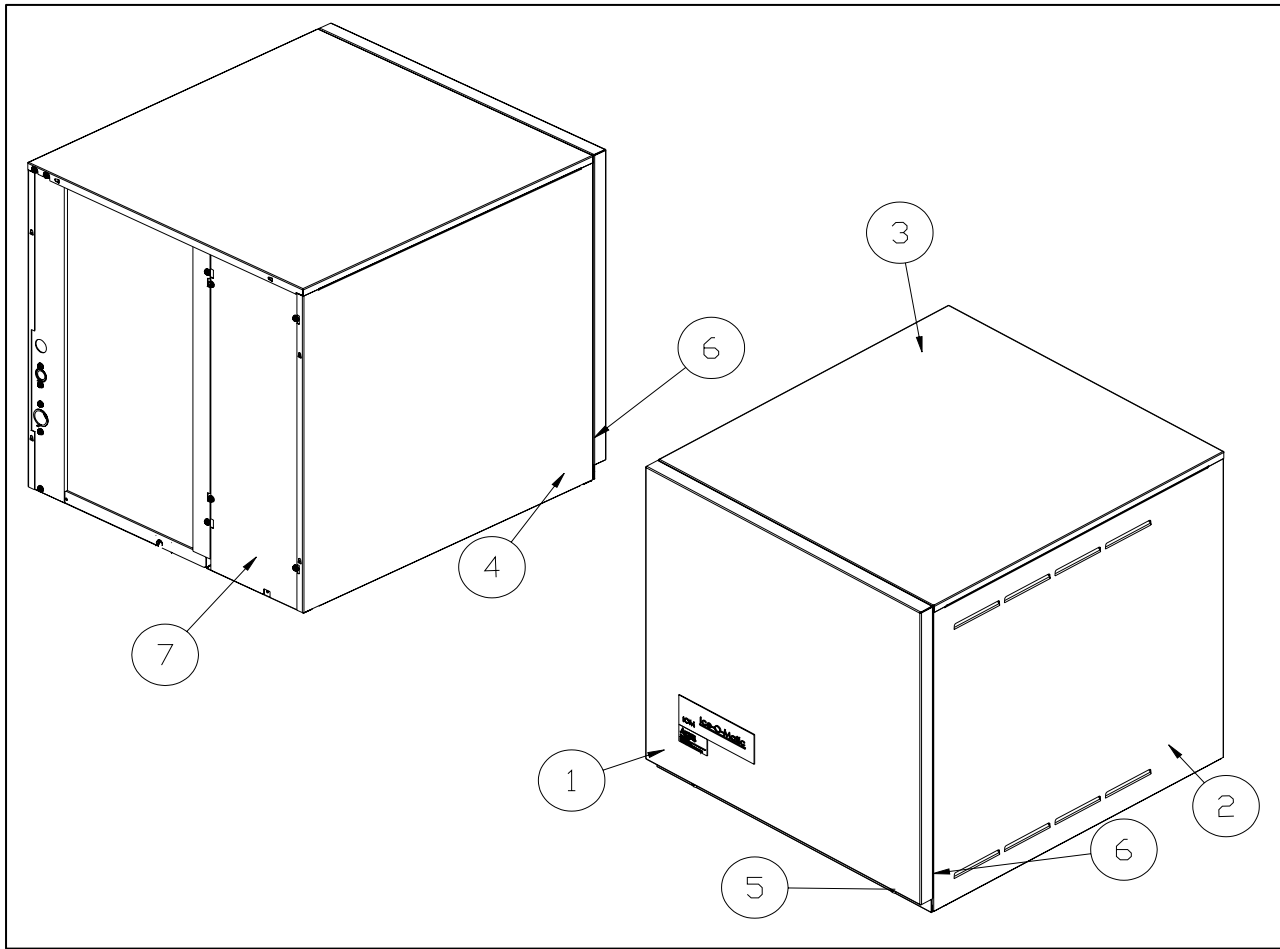

Item No.	Description	Part Number
1	Front Panel	2031490-01S
2	Right Hand Side Panel	3021831-01
2	Right Hand Side Panel	3021862-01
3	Top Panel	3021847-01
4	Left Hand Side Panel	2101330-01S
5	Front Panel Screw	9031098-03
6	Side Panel Screw	9031046-01
7	Rear Cover Panel	3021838-01
	Plastic Nut	9031141-01

Air Cooled Only
Water Cooled Only

Air Cooled Only

ICE0320/0520 Service Parts

ICE0320 Air Cooled

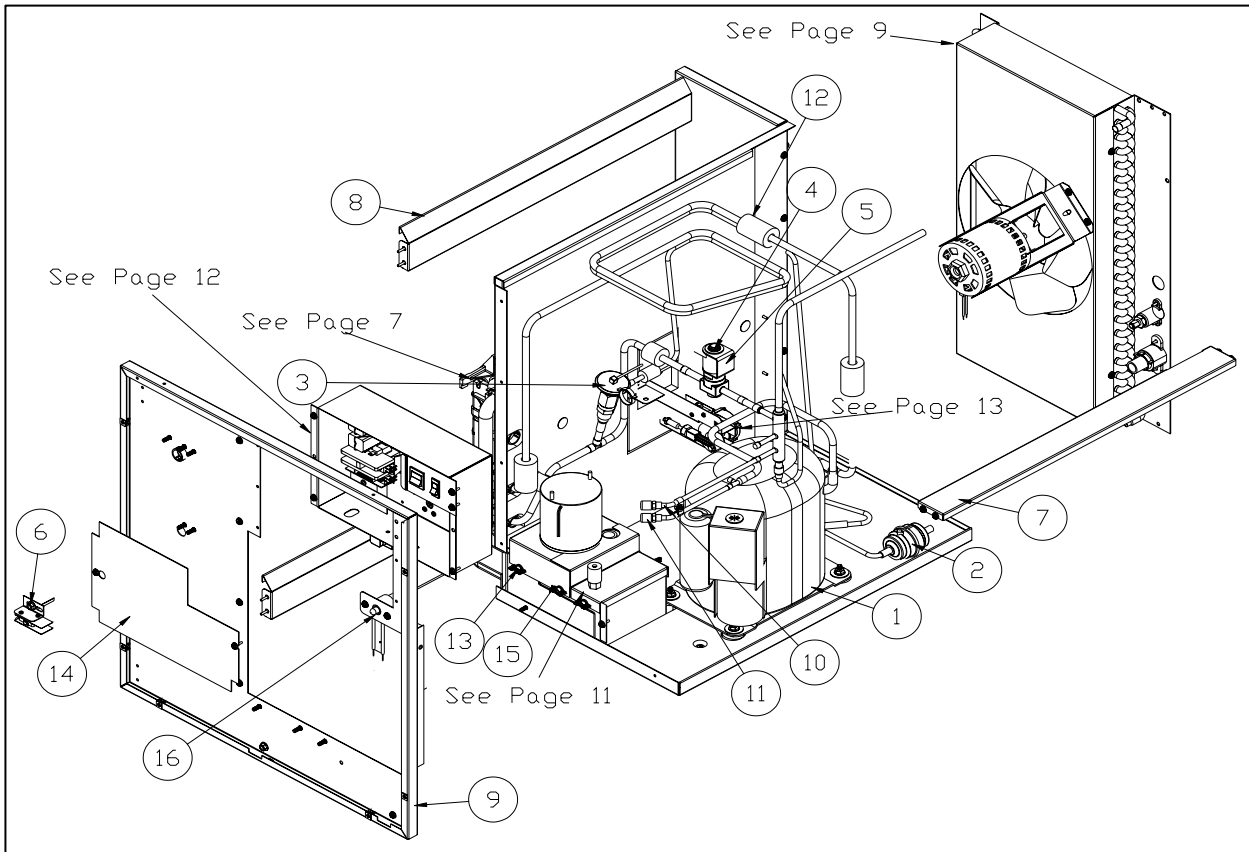

Item No.	Description	Part Number	
1	Compressor Kit	9181121-11	ICE0320
1	Compressor Kit	9181122-11	ICE0325
2	Filter-Drier	9151004-02	
3	Expansion Valve	9151006-21	ICE0320A
3	Expansion Valve	9151134-04	ICE0320A Beginning Ser. Mid D2
3	Expansion Valve	9151134-04	ICE0325
4	Hot Gas Valve Body	9151123-01	
5	Hot Gas Valve Coil 115V	9151123-03	ICE0320
5	Hot Gas Valve Coil 230V	9151123-04	ICE0325
6	Bin Switch	3051230-01S	ICE0320, 0325, 0520 and 0525
6	Bin Switch	2061471-03S	ICE0320 and 0325 Beg. Ser. D422-00305-Z
7	Side Brace	3012965-01	
8	Ice Deflector	3012924-01	
9	Front Panel	2021577-01	
10	Service Valve Core	9091086-02	
11	Service Valve Cap	9091086-03	
12	High Temp Safety	9041087-03	
13	Nylon Wing Nut	9031161-01	
14	Control Box Cover	3012974-01	
15	Water Pan	9051478-01	
16	High Pressure Control	9041051-04	
	Wtr Pan Screw (3 Req'd)	9031046-24	

ICE0320/0520 Service Parts

ICE 0520 Air Cooled

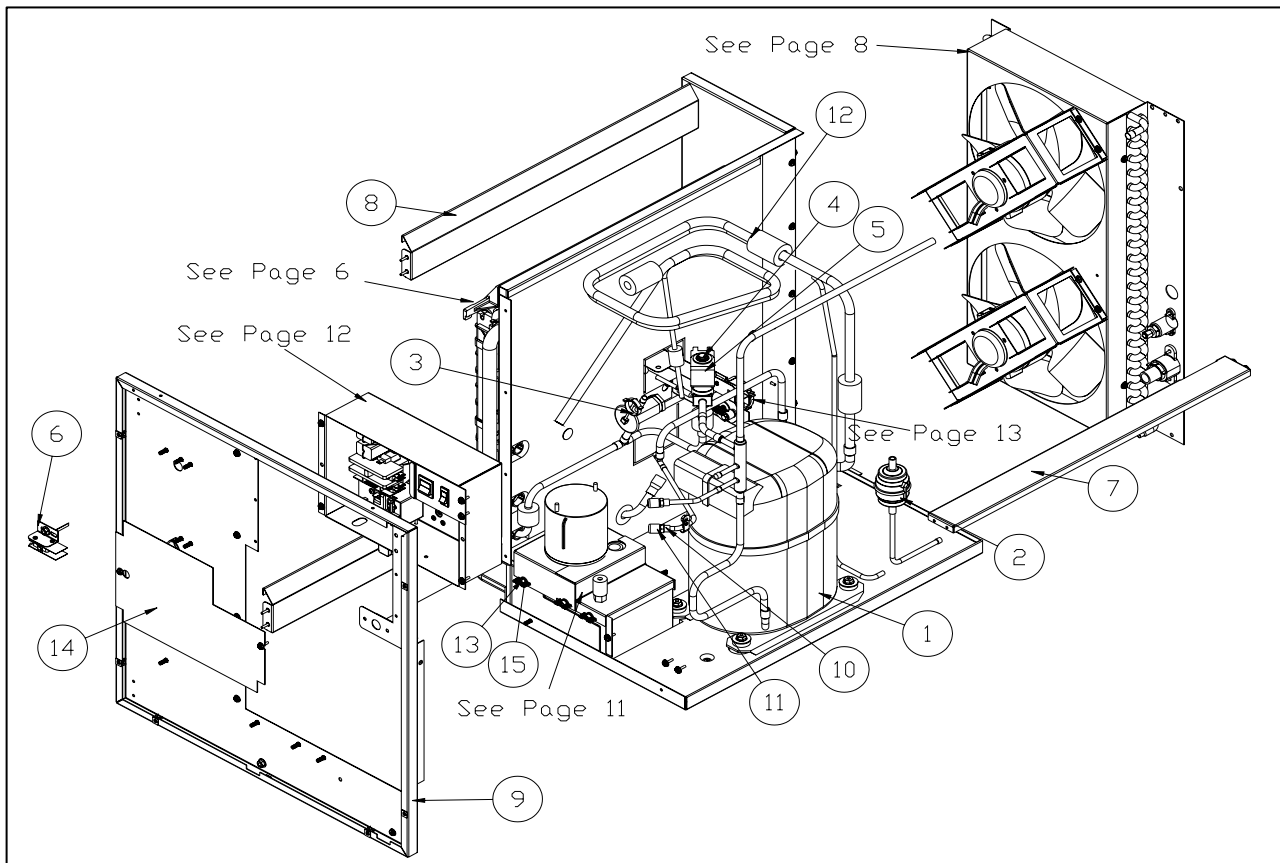

Item No.	Description	Part Number	
1	Compressor Kit	9181086-11	ICE0520
1	Compressor Kit	9181116-11	ICE0525
2	Filter-Drier	9151004-02	
3	Expansion Valve	9151006-08	ICE0520
3	Expansion Valve	9151134-01	ICE0520 Beginning Ser. A2
3	Expansion Valve	9151134-01	ICE0525
4	Hot Gas Valve Body	9151123-01	
5	Hot Gas Valve Coil 115V	9151123-03	ICE0520
5	Hot Gas Valve Coil 230V	9151123-04	ICE0525
6	Bin Switch	3051230-01	
6	Bin Switch	2061471-03S	ICE0520 and 0525 Beg. Ser. D423-00320-Z
7	Side Brace	3012965-01	
8	Ice Deflector	3012924-01	
9	Front Panel	2021577-01	
10	Service Valve Core	9091086-02	
11	Service Valve Cap	9091086-03	
12	High Temp Safety	9041087-03	
13	Nylon Wing Nut	9031161-01	
14	Control Box Cover	3012974-01	
15	Water Pan	9051478-01	
	Wtr Pan Screw (3 Req'd)	9031046-24	

ICE0320/0520 Service Parts

Water Cooled

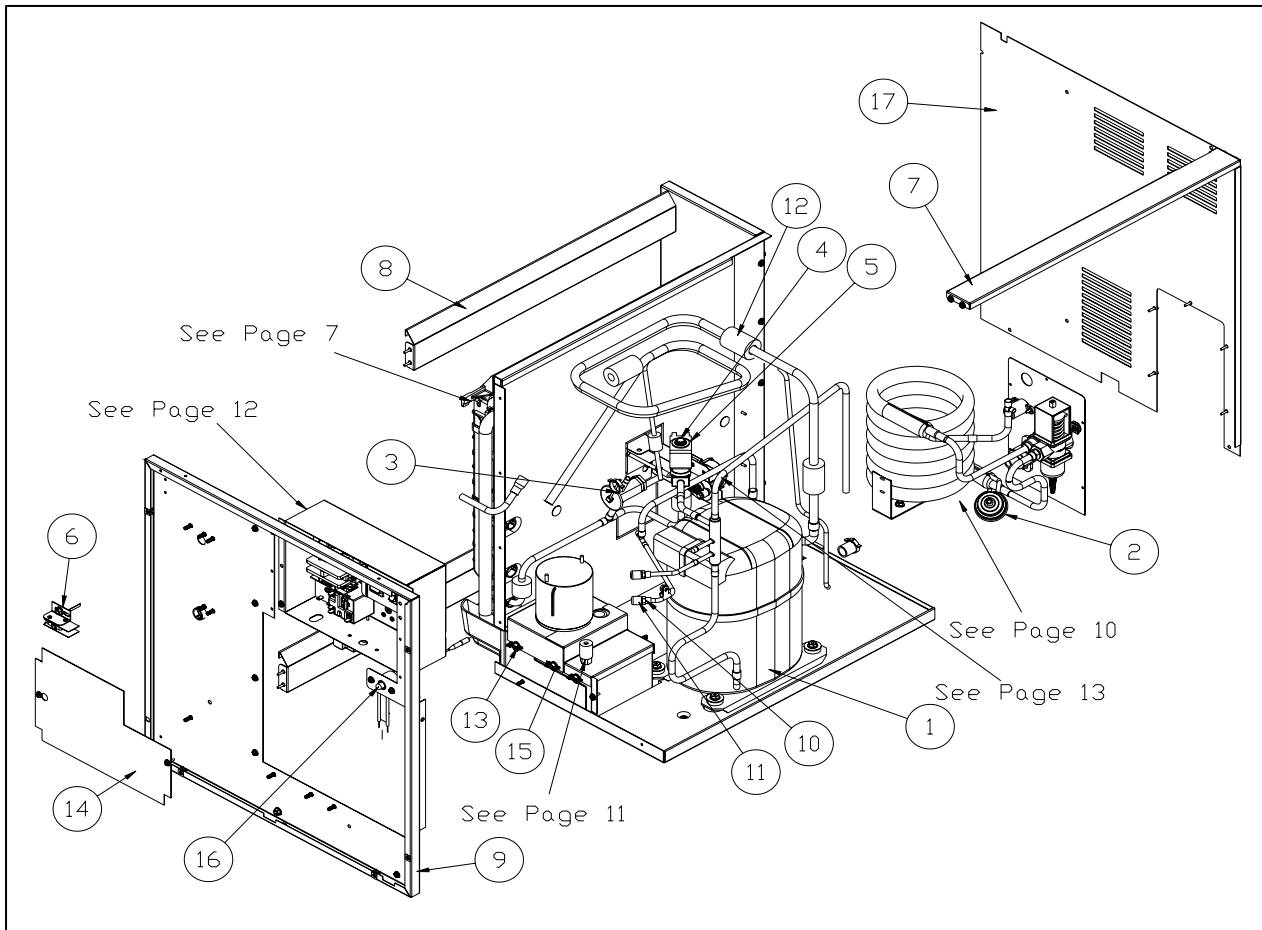

Item No.	Description	Part Number	
1	Compressor Kit	9181121-11	ICE0320
1	Compressor Kit	9181086-11	ICE0520
2	Filter-Drier	9151004-02	
3	Expansion Valve	9151006-21	ICE0320
3	Expansion Valve	9151134-01	ICE0520
4	Hot Gas Valve Body	9151123-01	
5	Hot Gas Valve Coil 115V	9151123-03	
6	Bin Switch	3051230-01	
6	Bin Switch	2061471-03S	ICE0320 and 0325 Beg. Ser. D422-00305-Z
6	Bin Switch	2061471-03S	ICE0520 and 0525 Beg. Ser. D423-00320-Z
7	Side Brace	3012965-01	
8	Ice Deflector	3012924-01	
9	Front Panel	2021577-01	
10	Service Valve Core	9091086-02	
11	Service Valve Cap	9091086-03	
12	High Temp Safety	9041087-03	
13	Nylon Wing Nut	9031161-01	
14	Control Box Cover	3012974-01	
15	Water Pan	9051478-01	
16	High Pressure Control	9041051-04	
17	Rear Panel	3021863-01	

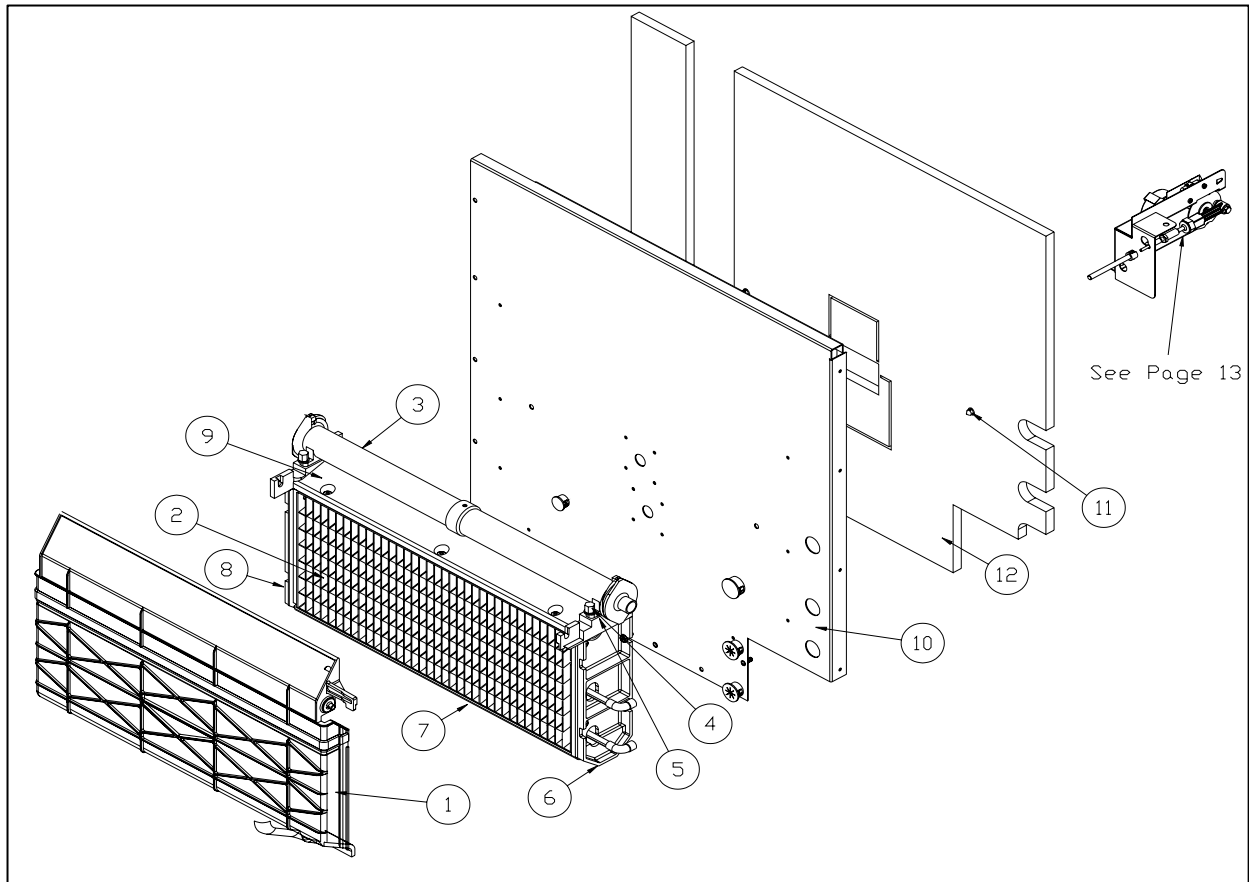

Item No.	Description	Part Number
1	Splash Curtain	3051233-02
2	Evaporator-Half	2051222-02S
2	Evaporator-Full	2051222-01S
3	Water Dist. Tube	2041338-02
4	Thumb Screw	9031122-01
5	Rubber washer	9031004-19
6	Evap Side Panel RH	9051136-08
7	Water Return	9051135-04
8	Evap Side Panel LH	9051136-07
9	Spillway	9051135-05
10	Center Panel	2021601-01
11	Insulation Clip	9031154-01
12	Insulation	9131413-01

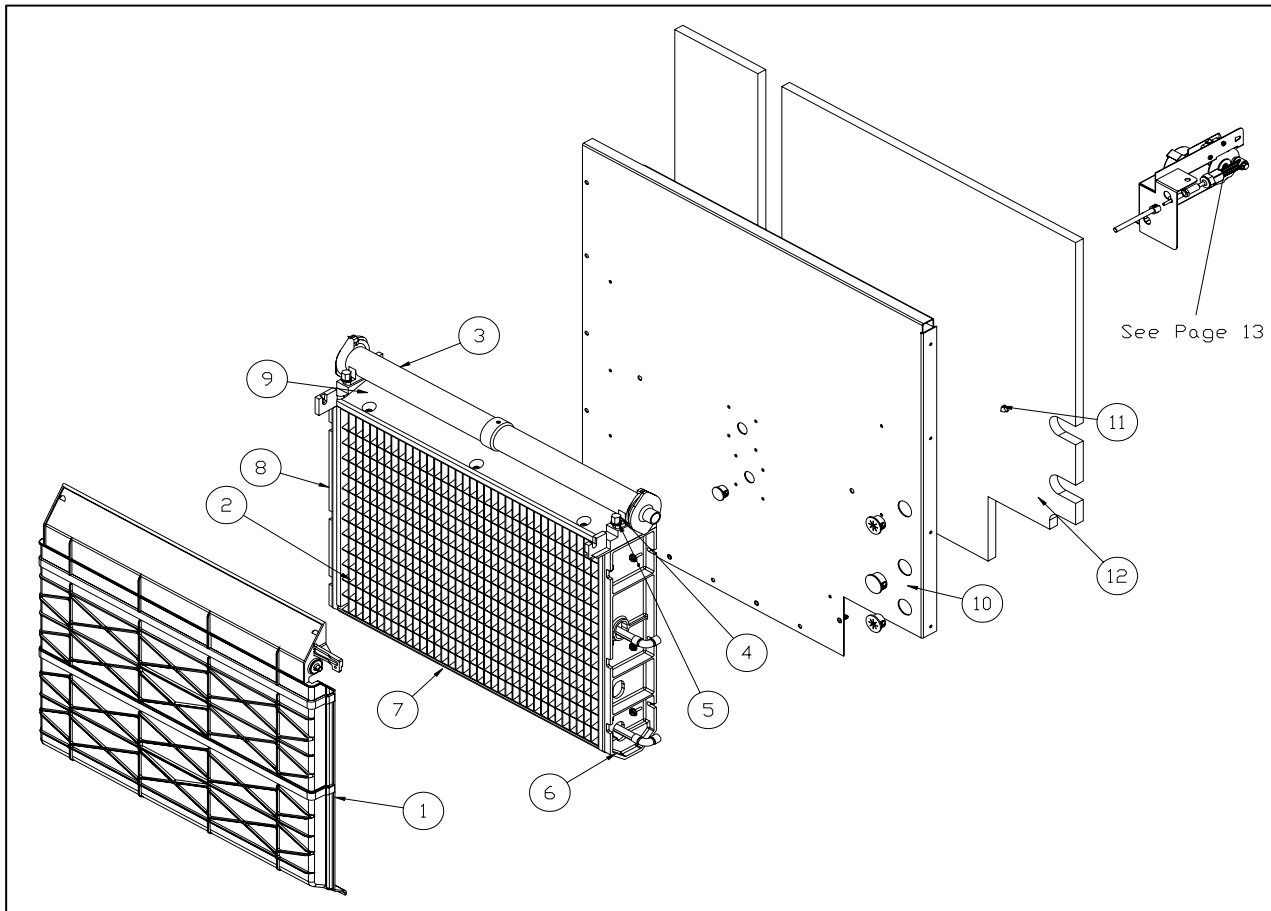

Item No.	Description	Part Number
1	Splash Curtain	2101355-04S
2	Evaporator-Half	2051147-82
2	Evaporator-Full	2051147-81
3	Water Dist. Tube	2041338-02
4	Thumb Screw	9031122-01
5	Rubber washer	9031004-19
6	Evap Side Panel RH	9151136-06
7	Water Return	9051135-04
8	Evap Side Panel LH	9051136-05
9	Spillway	9051135-05
10	Center Panel	2021601-01
11	Insulation Clip	9031154-01
12	Insulation	9131413-01

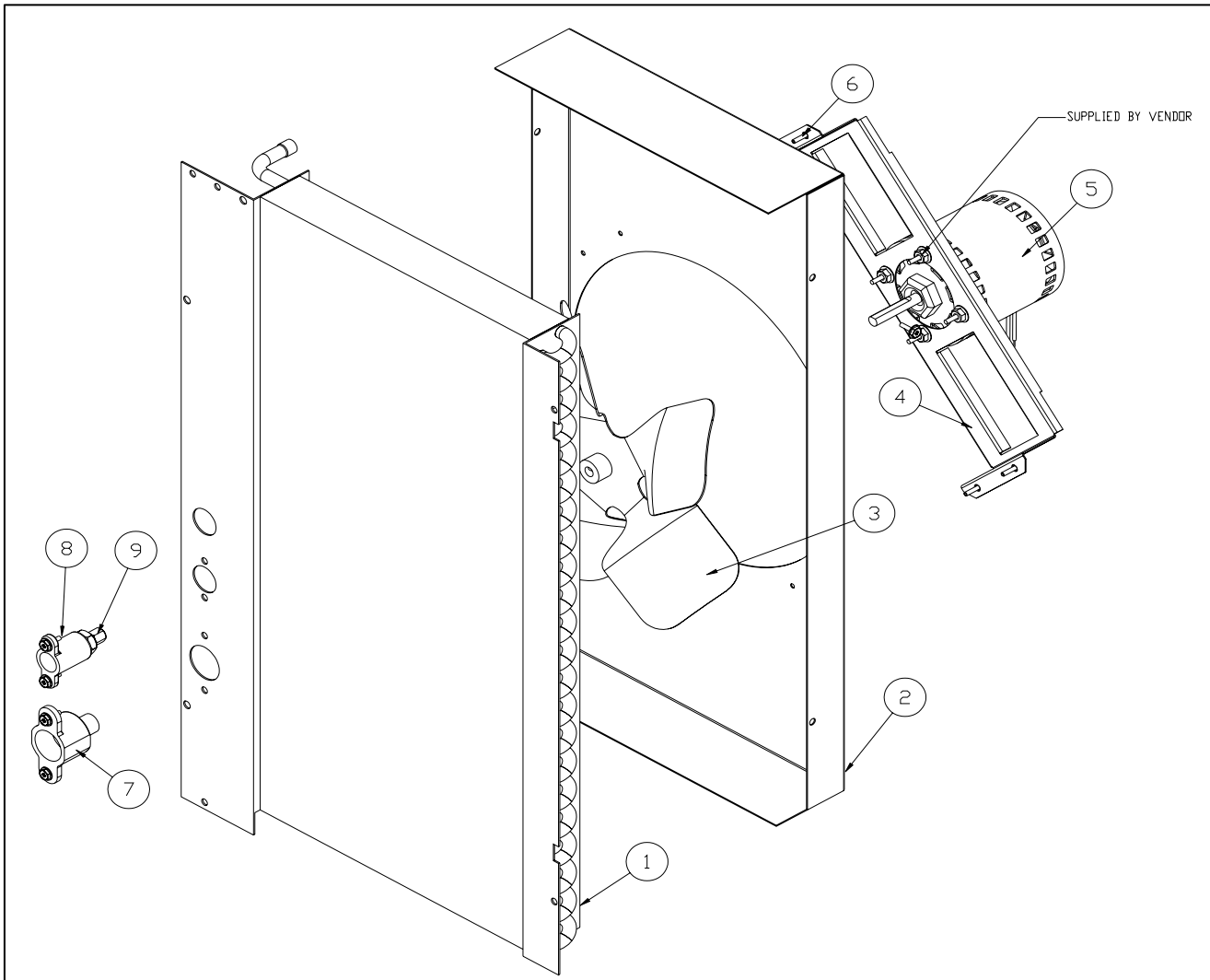

Item No.	Description	Part Number	
1	Air Condenser	9141118-01	
2	Fan Shroud	3013111-01	
3	Fan Blade	9131225-01	ICE0320
3	Fan Blade	9131384-04	ICE0325
4	Fan Motor Bracket	3013059-01	ICE0320
4	Fan Motor Bracket	2021612-01	ICE0325
5	Fan Motor 115V	9161089-02	ICE0320
5	Fan Motor 230V	9161078-02	ICE0325
6	#10-16X1/2 Screw	9031046-01	
7	Drain Fitting	9091119-01	
8	Drop Adapter	9091074-01	
9	Water Inlet Fitting	9091083-01	

ICE0320/0520 Service Parts

ICE0520/0525 Air Cooled Only

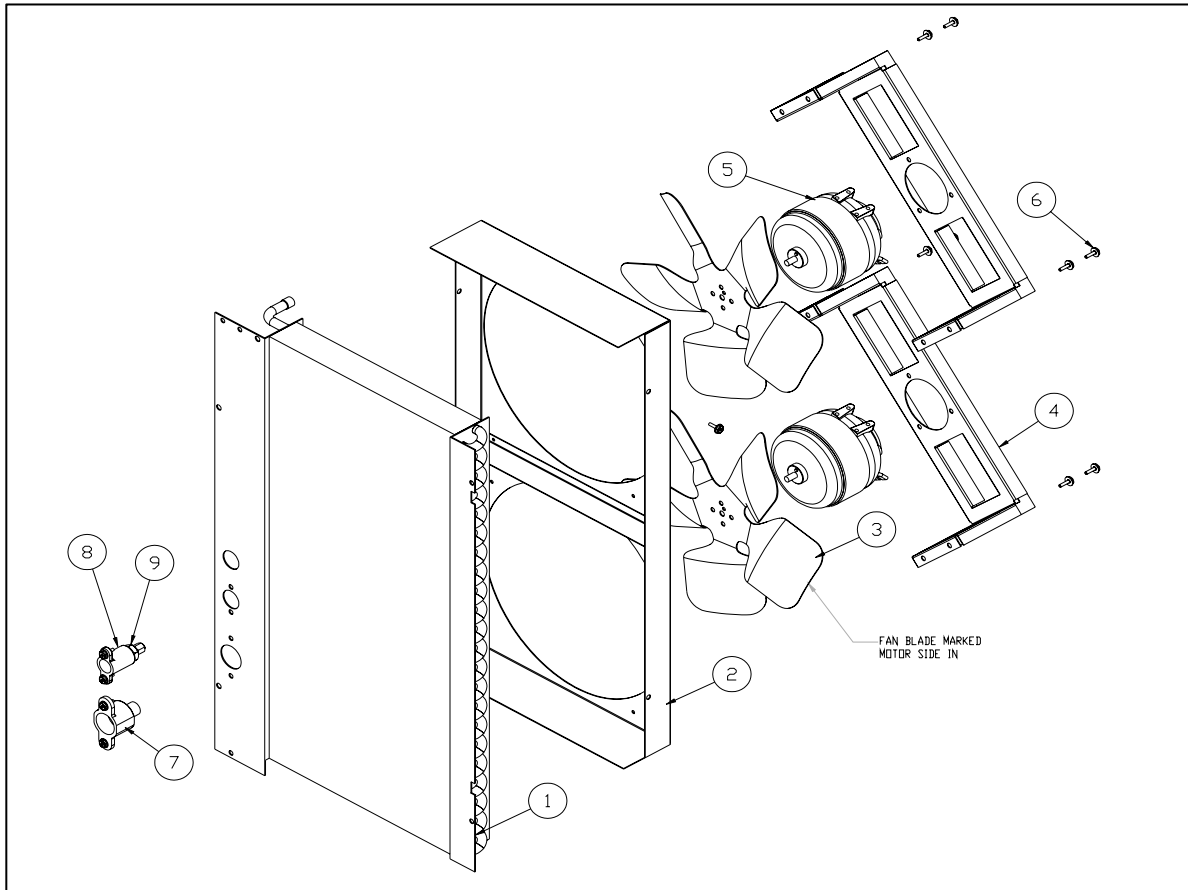

Item No.	Description	ICE 0520	ICE 0525
1	Air Condenser	9141117-01	9141117-01
1	Air Condenser Beg. Ser. A2	9141118-01	9141118-01
2	Fan Shroud	2021613-01	2021613-01
3	Fan Blade	9131225-01	9131225-01
3	Fan Blade Beg. Ser A2	9131384-04	
4	Fan Motor Bracket	3013059-01	3013059-01
4	Fan Motor Bracket Beg. Ser. A2	2021612-01	
5	Fan Motor 115V*	9161108-01*	
5	Fan Motor 115V Beg. Ser. A2	9161112-01	
5	Fan Motor 230V		9161078-02
6	#10-16X1/2 Screw	9031046-01	9031046-01
7	Drain Fitting	9091119-01	9091119-01
8	Drop Adapter	9091074-01	9091074-01
9	Water Inlet Fitting	9091083-01	9091083-01

*** NOTE:**

When replacing a Fan Motor on the ICE0520 in the field, 9161112-01 Fan Motor, 9131384-01 Fan Blade and 2021612-01 Fan Bracket **MUST** be used in the replacement.

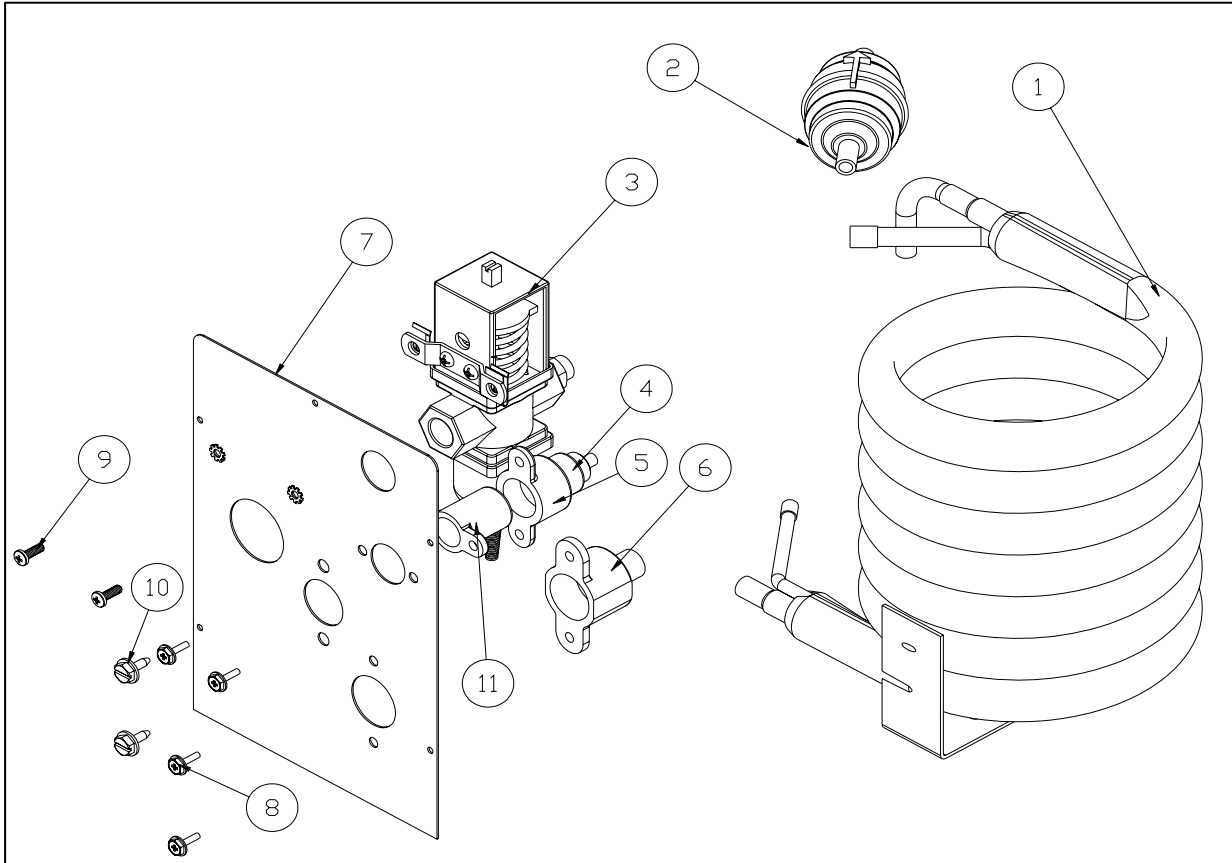

Item No.	Description	Part Number
1	Water Condenser	9141119-01
2	Filter/Drier	9151004-02
3	Water Regulator	9041059-01
4	Reducer Fitting	9091014-09
5	Drop Adapter	9091063-02
6	Drain Fitting	9091119-01
7	Bracket	3013079-01
8	#10-16 X 1/2 Screw	9031046-01
9	Pan Head Screw	9031008-07
10	1/4-20 X 1/2 Screw	9031019-04
11	Drop Adapter	9091074-01

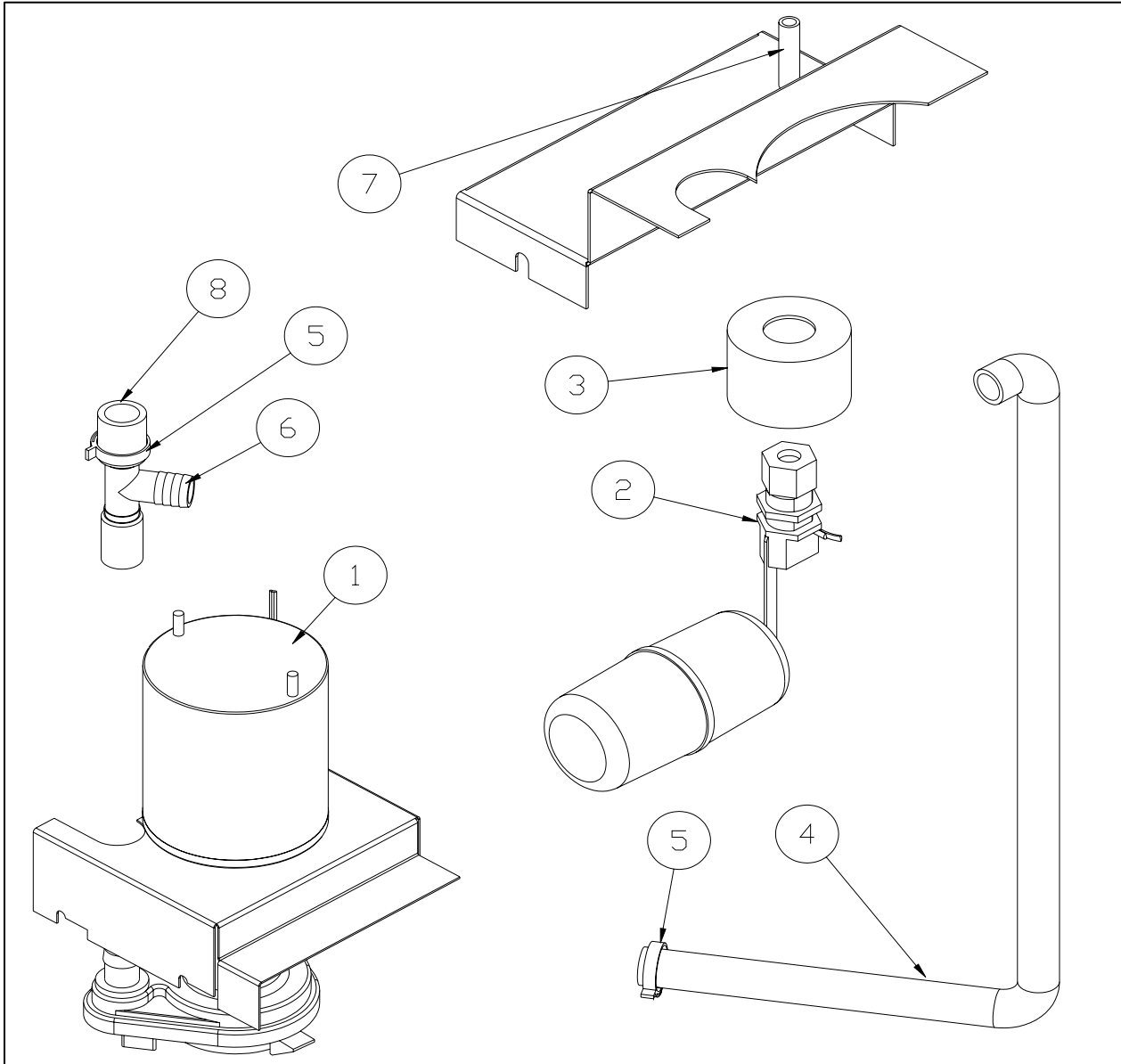

Item No.	Description	Part Number	
1	Water Pump 115V	9161076-01	ICE0320
1	Water Pump 230V	9151076-02	ICE0325
1	Water Pump 115V	9161076-01	ICE0520
1	Water Pump 230V	9161079-03	ICE0525
	Thumbscrew for Pump (2 Req)	9161076-101	
2	Float Assembly	9131111-01	
3	Splash Shield	9131026-02	
4	Water Tube, Evap	9051506-02	ICE0320/0325
4	Water Tube, Evap	9051506-01	ICE0520/0525
5	Plastic Clamp	9021010-04	
6	Barbed Tee	9091024-01	
7	1/4" Tube 24.00" Lg	3032898-24	
8	5/8" ID X 10" Tube	3051223-10	

Please note: Thumbscrews are shipped with the Water Pump when ordered as a service replacement part.

ICE0320/0520 Service Parts

Control Box

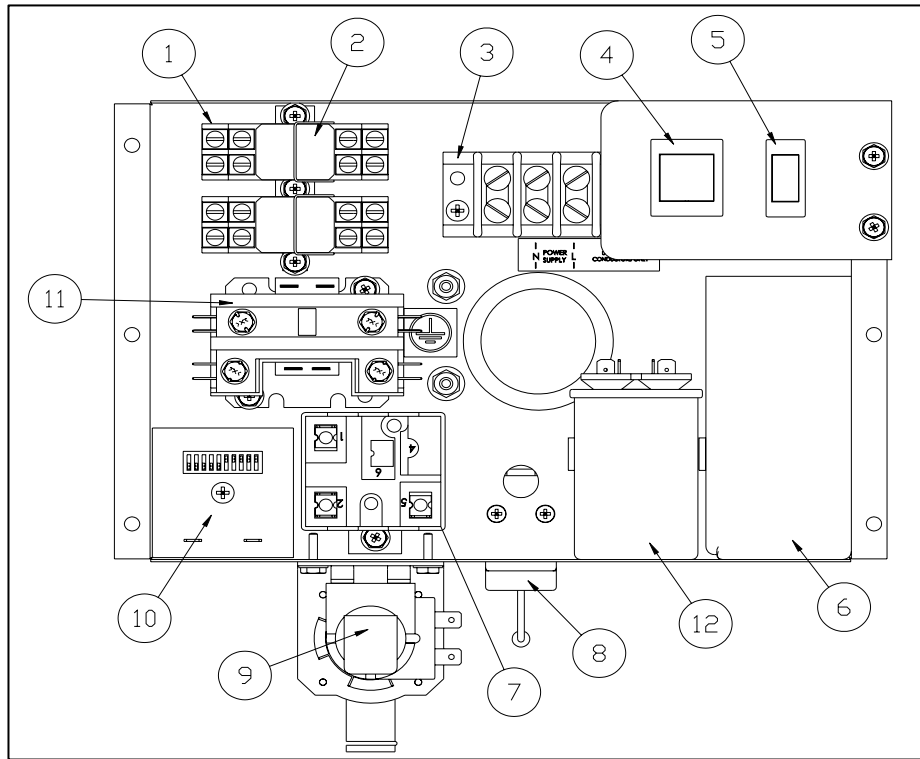

Item No.	Description	Part Number	
1	Relay Socket	9101083-01	
2	Relay 115 Volt	9101084-01	ICE0320/0520
2	Relay 230 Volt	9101084-02	ICE0325/0525
3	Terminal Board	9101037-01	
4	On-Off Wash Switch	9101195-01	
5	Purge Switch	9101139-03	
6	Start Capacitor	9181003-39	ICE0320
6	Start Capacitor	9181003-17	ICE0520
6	Start Capacitor	9181003-40	ICE0325
6	Start Capacitor	9181003-04	ICE0525
7	Current relay	9181004-27	ICE0320
7	Potential Relay	9181010-14	ICE0520
7	Potential Relay	9181010-26	ICE0325
7	Potential Relay	9181010-04	ICE0525
8	Low Pressure Control	9041094-01	
9	Purge Valve 115V	9041086-04	ICE0320/520
9	Purge Valve 230V	9041086-05	ICE0325/525
10	Timer	9101148-01	
11	Contactors 115V	9101002-07	ICE0320/520
11	Contactors 230V	9101002-06	ICE0325/525
12	Run Capacitor	9181009-08	ICE0325
12	Run Capacitor	9181009-09	ICE0525
	High Temp Safety	9041087-03	
	High Pressure Control	9041051-04	
	Water Pump Cord	9101218-11	

ICE0320/0520 Service Parts

Old Style Harvest Assist Assembly

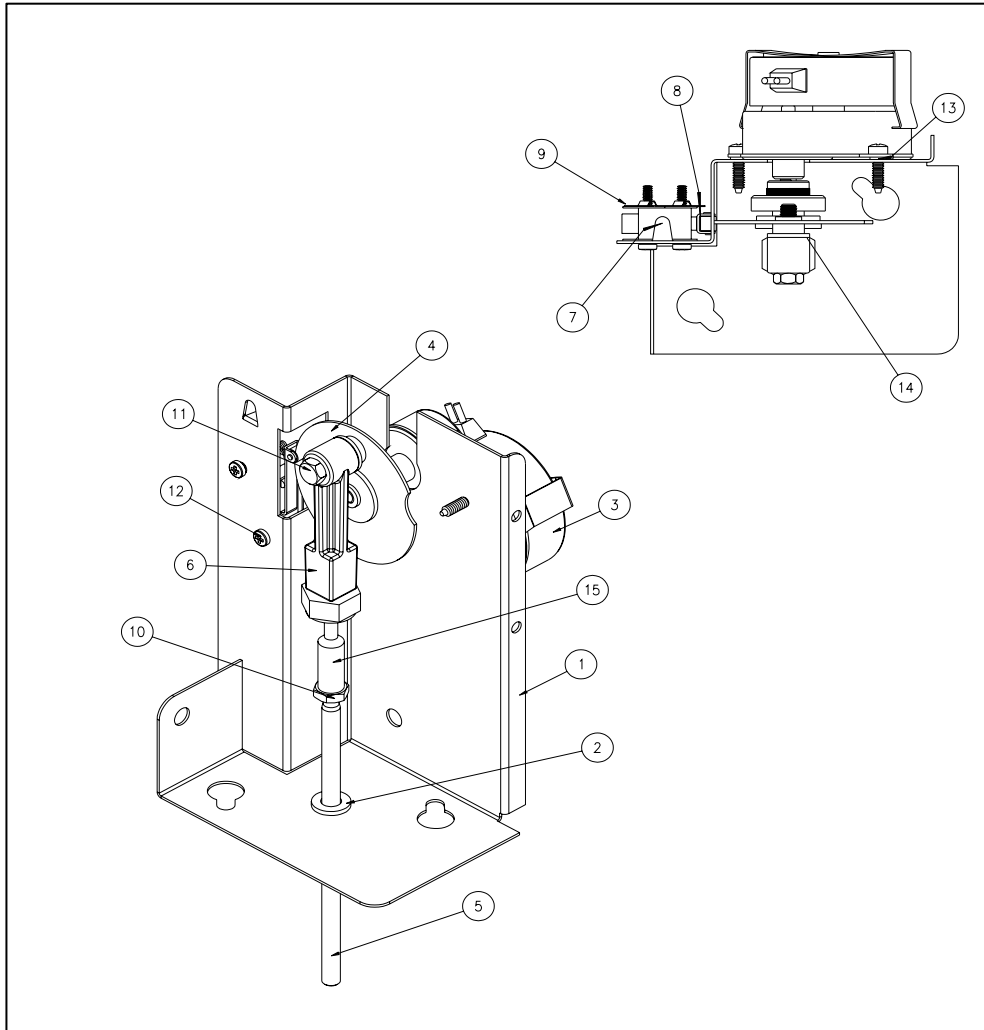

Item No.	Description	ICE0320 ICE0520	ICE0325 ICE0525
1	Probe Motor Bracket	3012890-01	3012890-01
2	Snap Bushing	9051001-13	9051001-13
3	Gear Motor-115 Volt	9161030-01	
3	Gear Motor-230 Volt		9161031-01
4	Clutch Assembly-180 Degree	9131190-01	9131190-01
5	Probe Shaft	9131189-03	9131189-03
5	One Piece Shaft & Swivel	9021102-01	9021102-01
6	Connecting Rod	9051057-01	9051057-01
7	Cam Switch	9101160-01	9101160-01
8	Speed Nut Plate	9031120-01	9031120-01
9	Insulation, Switch	3051145-01	3051145-01
10	#10-32 Hex Nut	9031005-03	9031005-03
11	Shoulder Screw	9031119-01	9031119-01
12	Pan Head Machine Screw	9031008-16	9031008-16
13	Self Tapping Screw	9031019-05	9031019-05
14	Flat Washer	9031003-03	9031003-03
	Complete Assy 115V	2061962-01S	
	Complete Assy 230V		2061962-02S

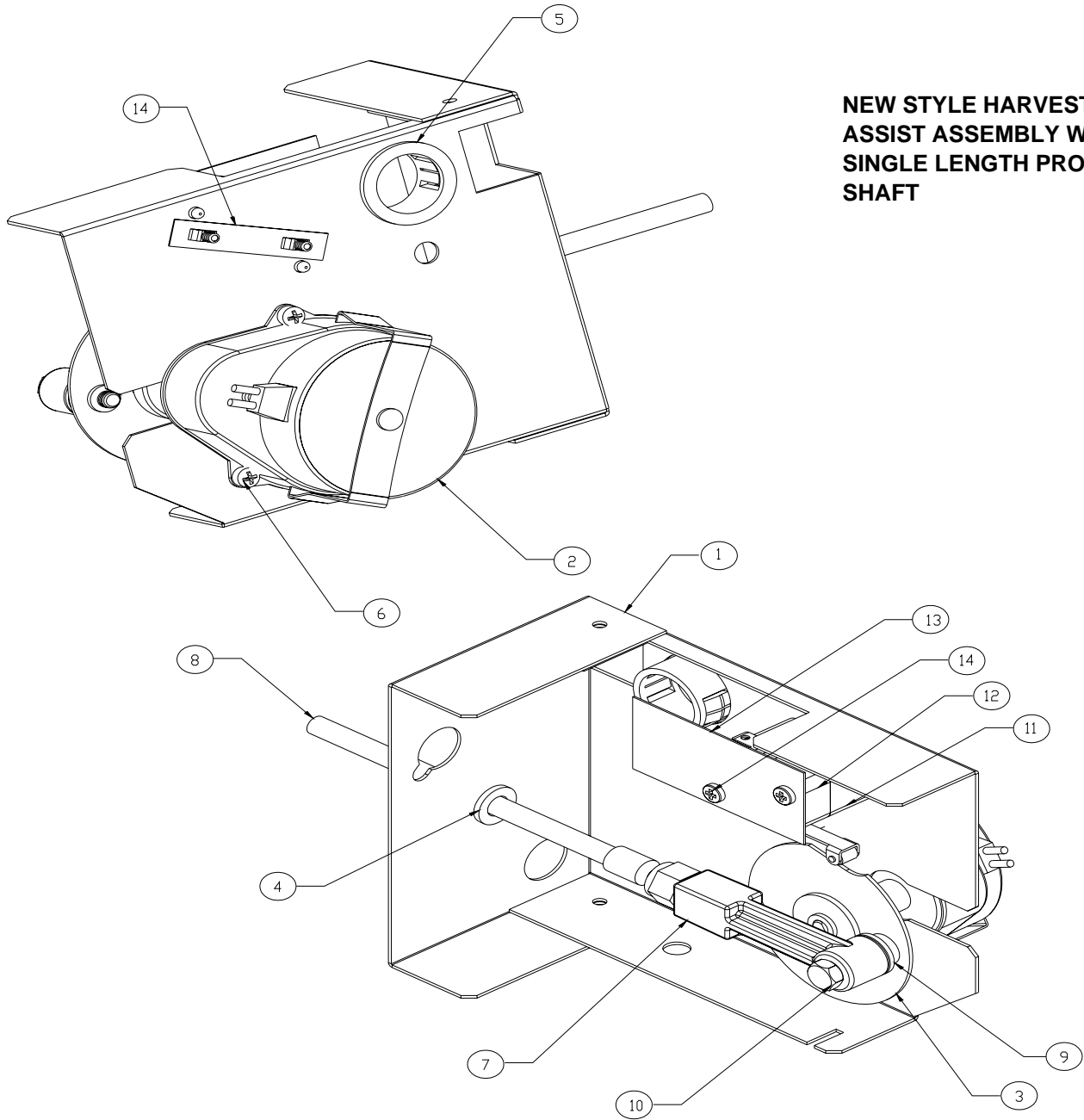

**NEW STYLE HARVEST
ASSIST ASSEMBLY W/
SINGLE LENGTH PROBE
SHAFT**

ICE0320/0520 Service Parts

New Style Harvest Assist Assembly

Item No.	Description	Model Number	
		ICE0320	ICE0520
1	Bracket, Probe Motor	3013170-01	3013170-01
2	Gear Motor	9161030-01	9161030-01
3	Clutch Assembly, 180 Deg	9131190-01	9131190-01
4	Snap Bushing	9051001-13	9051001-13
5	Snap Bushing	9051001-03	9051001-03
6	#6-32 x 1/2 Screw	9031019-08	9031019-08
7	Connecting Rod	9051057-01	9051057-01
8	Probe, Single Length	9021102-01	9021102-01
9	Flat Washer	9031003-03	9031003-03
10	Shoulder Screw	9031119-01	9031119-01
11	Spacer, Cam Switch	9051519-01	9051519-01
12	Cam Switch	9101160-01	9101160-01
13	Insulator	3051145-02	3051145-02
14	Pan Head Screw	9031008-44	9031008-44
15	Speed Nut Plate	9031120-01	9031120-01
	Complete Assembly	2061962-01S	2061962-01S

Please Note: The 2061962-XX is a direct replacement for the 2061620-XX Harvest Assist Assembly, however the Swivel/Shaft and Nut is **NOT** directly replaced by the new 9021102-01 One Piece Probe Shaft.

Item No.	Description	Model Number	
		ICE0325	ICE0525
1	Bracket, Probe Motor	3013170-01	3013170-01
2	Gear Motor	9161031-01	9161031-01
3	Clutch Assembly, 60 Deg	9131190-01	9131190-01
4	Snap Bushing	9051001-13	9051001-13
5	Snap Bushing	9051001-03	9051001-03
6	#6-32 x 1/2 Screw	9031019-08	9031019-08
7	Connecting Rod	9051057-01	9051057-01
8	Probe, Single Length	9021102-01	9021102-01
9	Flat Washer	9031003-03	9031003-03
10	Shoulder Screw	9031119-01	9031119-01
11	Spacer, Cam Switch	9051519-01	9051519-01
12	Cam Switch	9101160-01	9101160-01
13	Insulator	3051145-02	3051145-02
14	Pan Head Screw	9031008-44	9031008-44
15	Speed Nut Plate	9031120-01	9031120-01
	Complete Assembly	2061962-02S	2061962-02S

Please Note: The 2061962-XX is a direct replacement for the 2061620-XX Harvest Assist Assembly, however the Swivel/Shaft and Nut is **NOT** directly replaced by the new 9021102-01 One Piece Probe Shaft.

ICE0320/0520 Service Parts

Compressor Kit Information

ICE0320 Air and Water Cooled

Compressor Kit	9181121-11
Start Capacitor	9181003-39
Relay	9181004-27
Overload	9181005-37
Drier	9151004-02

ICE0325 Air Cooled

Compressor Kit	9181122-11
Start Capacitor	9181003-40
Run Capacitor	9181009-08
Relay	9181010-26
Overload	9181005-39
Drier	9151004-02

ICE0520 Air and Water Cooled

Compressor Kit	9161086-11
Start Capacitor	9181003-17
Relay	9181010-14
Overload	9181005-12
Drier	9151004-02

ICE0525 Air Cooled

Compressor Kit	9181116-11
Start Capacitor	9181003-04
Run Capacitor	9181009-09
Relay	9181010-04
Overload	9181005-36
Drier	9151004-02

Compressor Kits include Driers and all Start Componets

