



## **Ice Machine Parts List for Series Q600 Models**

**QR0600A**

**QD0692N**

**QR0601W**

**QY0604A**

**QR0690N**

**QY0605W**

**QD0602A**

**QY0694N**

**QD0603W**

## Q600 CONTROL BOX

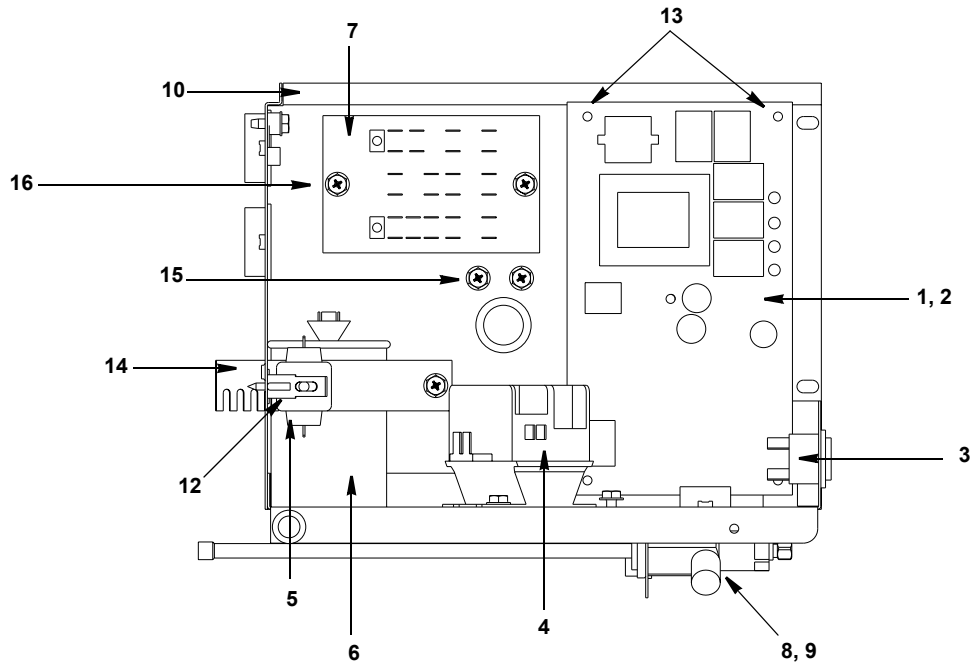

pt1176

### DESCRIPTION

DESCRIPTION	PART NO.
1 Control Board (for use with all voltages) . . . . .	† 76-2782-3
2 7 Amp Fuse – Mounted on Control Board . . . . .	25-1100-3
3 <b>Toggle Switch Only</b> . . . . .	23-0134-3
a. Toggle Switch with Wiring Harness Attached . . . . .	20-3217-3
4 Contactor (208-230V/60 Hz/1 Ph or 230V/50 Hz/1 Ph) . . . . .	† 20-0659-9
5 P.T.C.R. Compressor Starter . . . . .	85-0499-3
6 <b>Compressor Run Capacitor</b>	
a. 60 Hz for RS86CIE-PFV-251 . . . . .	85-0366-3
b. 60 Hz for RS86CIE-PFV-218 . . . . .	85-0393-3
c. 60 Hz for CS08KQE-PFV-255 . . . . .	85-0393-3
d. 50 Hz . . . . .	85-0393-3
7 <b>Terminal Board with Wire Harness Attached</b>	
a. 230V/60 Hz/1 Ph . . . . .	20-3229-3
b. 50 Hz/1 Ph . . . . .	20-3230-3
8 Refrigeration Service Valve Assembly . . . . .	83-7326-3
<b>Miscellaneous – Brackets, Screws, etc.</b>	
9 Locknut Used to Mount Refrigeration Service Valves . . . . .	† 54-7503-9
10 Control Box . . . . .	602559-1
11 Control Box Cover (Not shown) . . . . .	† 76-2852-3
12 P.T.C.R. Compressor Starter Mounting Bracket . . . . .	85-0501-3
13 Control Board Mounting Supports . . . . .	43-0225-3
14 Capacitor Mounting Strap . . . . .	602495-1
15 Screw, #10-24 x .50 Ground . . . . .	† 52-0216-9
16 Screw, #10-24 x .50 . . . . .	† 52-0206-9

† Refer to Cross Reference Guide

## Q600 EVAPORATOR COMPARTMENT

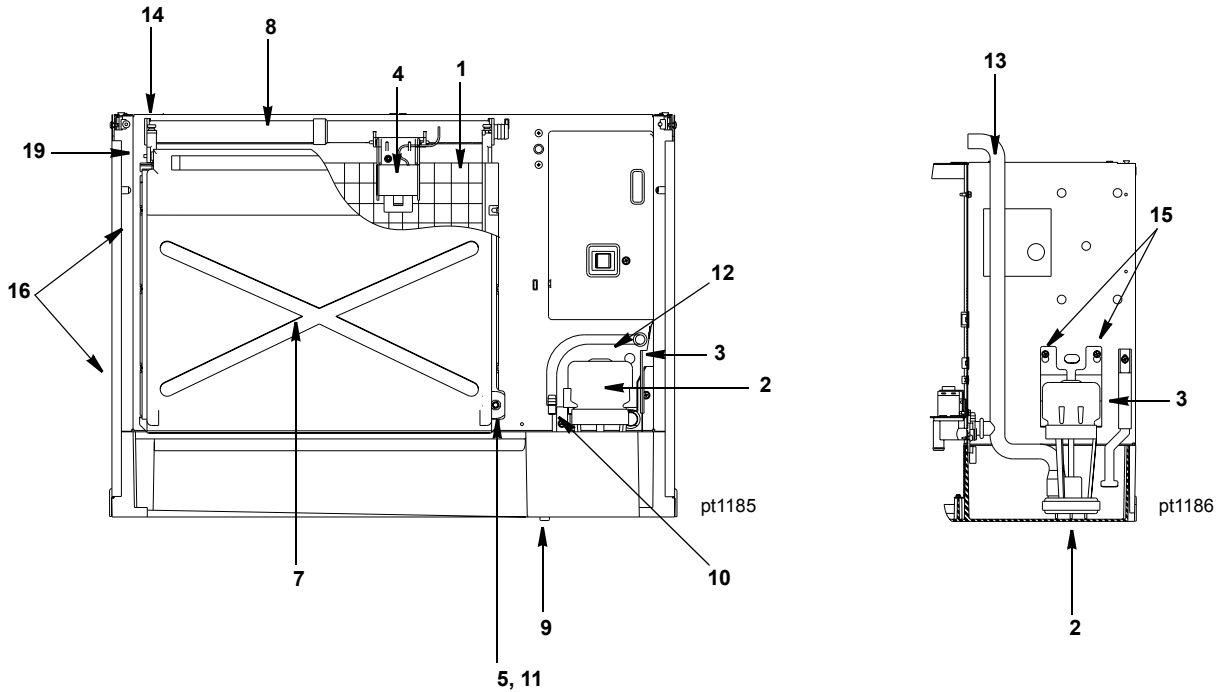

### DESCRIPTION

#### 1 Evaporator Assembly

	PART NO.
a. Regular Cube . . . . .	† 76-2512-9
b. Dice Cube . . . . .	† 76-2511-9
c. Half Dice Cube . . . . .	† 76-2510-9
2 Water Pump (208-230V/60 Hz or 230V/50 Hz) . . . . .	† 76-2601-3
3 Water Level Probe . . . . .	25-1129-3
4 Ice Thickness Control Probe . . . . .	† 76-2781-3
5 Magnetic Bin Switch (Mounted to Evaporator). . . . .	† 23-0148-3
6 Water Flow Clamp – Use on Regular Cube Evap. Only (Not shown) . . . . .	76-2054-3
7 Water Curtain . . . . .	† 43-0464-3
8 Water Distribution Tube . . . . .	† 76-2498-3
9 Water Trough Drain Plug . . . . .	† 43-0062-9
10 Water Inlet Flow Tube . . . . .	43-0388-3

#### Miscellaneous – Brackets, Screws, etc.

11 Water Curtain Magnet with Attachment Clip . . . . .	† 76-2802-3
12 Water Inlet Tubing .375 ID . . . . .	44-2111-3
13 Tubing (Water Pump Out) . . . . .	44-2109-3
14 Screw, #8-32 x .63 Nylon Water Distribution Tube Mounting. . . . .	† 50-0001-3
15 Screw, #10-24 x .50 . . . . .	† 52-0206-9
16 Screw, #10-24 x .750 Used to Mount Evaporator . . . . .	† 52-0218-9
17 Base and Water Trough Repair Kit . . . . .	† 76-2806-3
18 Evaporator Top Molding and Gasket Assembly . . . . .	76-2621-3
19 Water Curtain Pin Assembly . . . . .	76-2776-3

† Refer to Cross Reference Guide

## Q600 REFRIGERATION COMPARTMENT – COMMON PARTS

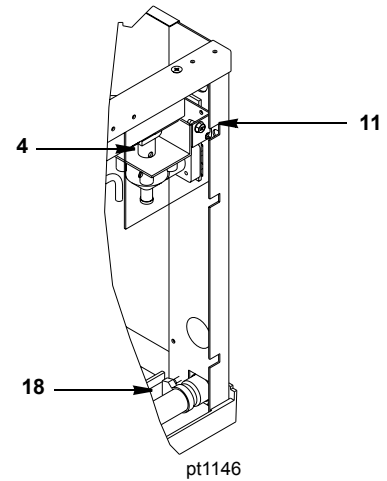
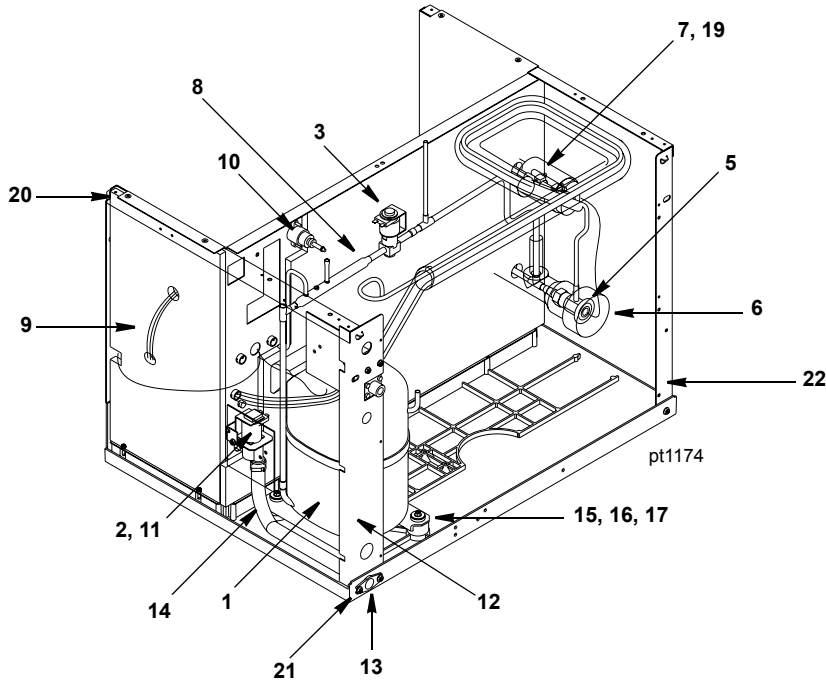

### DESCRIPTION

		PART NO.
1	<b>Compressor</b>	
	a. 208/230V 60 Hz/1 Ph .....	76-0092-3
	b. 230V/50 Hz/1 Ph .....	76-0091-3
2	<b>Water Dump Valve</b>	
	a. Dump Valve Assembly without Electrical Coil .....	† 24-0520-3
	b. Dump Valve Coil Only, 208/230V 50-60 Hz .....	24-0522-3
	c. Dump Valve Rebuild Kit .....	24-0501-3
3	<b>Hot Gas Valve</b>	
	a. Hot Gas Valve Including 208/230V 50/60 Hz Electrical Coil (Danfoss) .....	† 76-3010-1
	b. Hot Gas Valve 208/230V 50-60 Hz Coil Only Danfoss .....	20-0177-3
	c. Hot Gas Valve 208/230V 50-60 Hz Coil Only Alco .....	† 24-0448-3
4	<b>Water Inlet Valve</b>	
	a. Water Inlet Valve Including 208/230V 50-60 Hz Coil .....	† 76-0113-3
5	Expansion Valve .....	† 76-0020-3
6	Expansion Valve Body Insulation Boot	
	a. Alco .....	40-0721-3
	b. Danfoss .....	40-0036-3
7	Expansion Valve Bulb Insulation Boot .....	40-0720-3
8	Manifold Strainer - 3 Hole (in front of hot gas valve) .....	83-1015-3
	a. Manifold Strainer - 4 Hole (in front of hot gas valve) .....	82-5096-3
9	Water Pump Electrical Wire Lead .....	† 20-7810-3
10	High Pressure Cut-out (Manual Reset) .....	† 23-5536-9
10	High Pressure Cut-out (Auto Reset) .....	† 20-0124-3
<b>Miscellaneous – Brackets, Screws, etc.</b>		
11	Dump Valve/Water Inlet Valve Mounting Bracket .....	602354-1
12	Right Corner Post Weldment .....	601950-1
13	Water Drain Female Wing Adapter .....	87-0608-3
14	Water Drain Vinyl Tubing, .625 ID .....	† 44-2038-3
15	Compressor Mounting Rubber Grommet .....	† 85-0306-9
16	Compressor Mounting Washer .....	† 55-7341-9
17	Compressor Mounting Screw .....	† 50-1230-9
18	Clamp, Water Drain .....	† 56-5070-9
19	Clamp, Expansion Valve Bulb .....	† 56-5052-9
20	Screw, #10-24 x .50 .....	† 52-0209-9
21	Screw, #10-24 x .75 .....	† 52-0218-9
22	Left Corner Post Weldment .....	601951-1
23	Terminal Block (50 Hz only) .....	20-0614-3

† Refer to Cross Reference Guide

## Q600 REFRIGERATION COMPARTMENT – AIR-COOLED

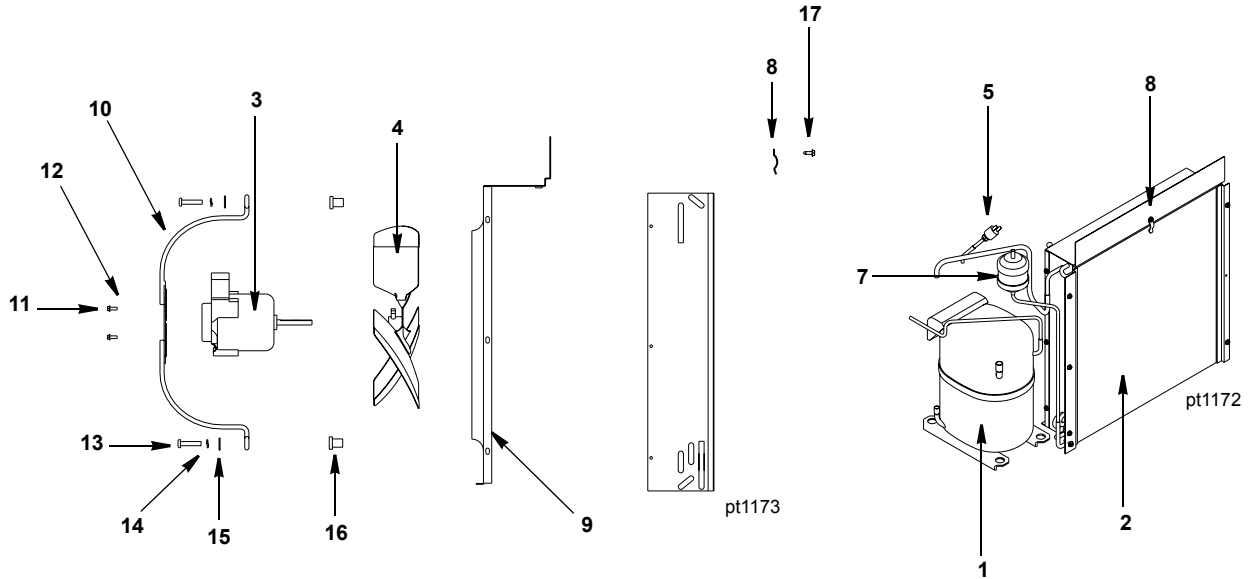

### DESCRIPTION

	<b>PART NO.</b>
1 Compressor (Refer to COMMON PARTS Page) . . . . .	Page 4
2 Air Condenser . . . . .	88-5125-3
3 Fan Motor (208-230V/60 Hz or 230V/50 Hz) . . . . .	† 24-1293-9
4 Fan Blade . . . . .	24-1617-3
5 Fan Cycling Control . . . . .	† 20-0126-3
6 Air Filter (Not shown) . . . . .	40-4018-3
7 Drier . . . . .	† 89-3025-9

### Miscellaneous – Brackets, Screws, etc.

8 Air Filter Clip . . . . .	† 56-5069-9
9 Fan Shroud . . . . .	601880-1
10 Fan Motor Mounting Bracket . . . . .	34-0662-3
11 Fan Motor Mounting Screw . . . . .	† 50-2559-9
12 Fan Motor Mounting Flatwasher . . . . .	† 55-0426-9
13 Fan Bracket Mounting Screw . . . . .	† 50-3358-9
14 Fan Bracket Mounting Lockwasher . . . . .	† 55-4510-9
15 Fan Bracket Mounting Flatwasher . . . . .	† 55-7305-9
16 Fan Bracket Mounting Rubber Wellnut . . . . .	† 54-2955-9
17 Screw, #10-24 x .75 . . . . .	† 52-0218-9

† Refer to Cross Reference Guide

## Q600 REFRIGERATION COMPARTMENT – WATER-COOLED

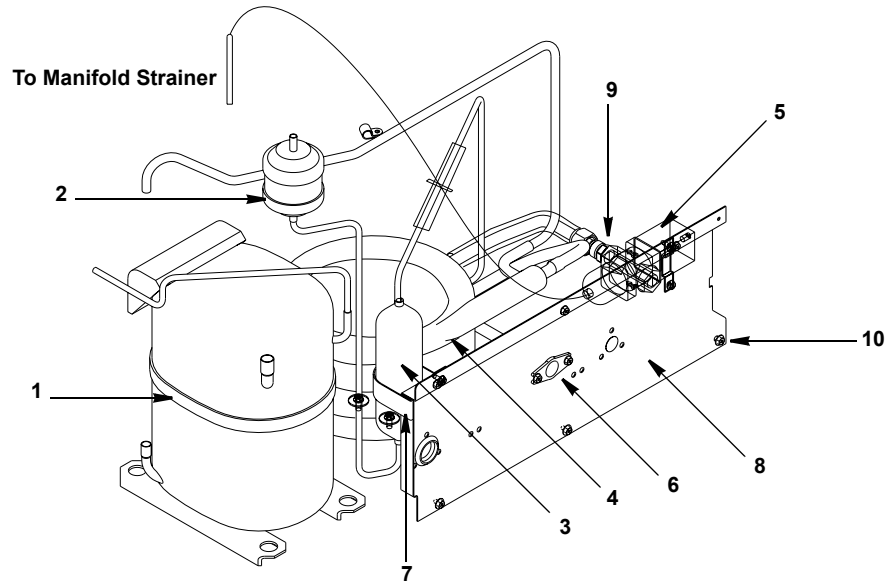

pt1180

### DESCRIPTION

DESCRIPTION	PART NO.
1 Compressor (Refer to COMMON PARTS Page) .....	Page 4
2 Drier .....	† 89-3025-9
3 Receiver .....	12-0003-1
4 Water-cooled Condenser .....	† 88-6533-3
5 Water Regulating Valve .....	† 83-7206-9
6 Water Drain Female Wing Adapter .....	87-0608-3

### Miscellaneous – Brackets, Screws, etc.

7 Receiver Strap .....	600054-1
8 Back Panel .....	601906-1
9 Water Coupling .....	83-3203-3
10 Screw, #10-24 x .75 .....	† 52-0218-9

## Q600 REFRIGERATION COMPARTMENT – REMOTE

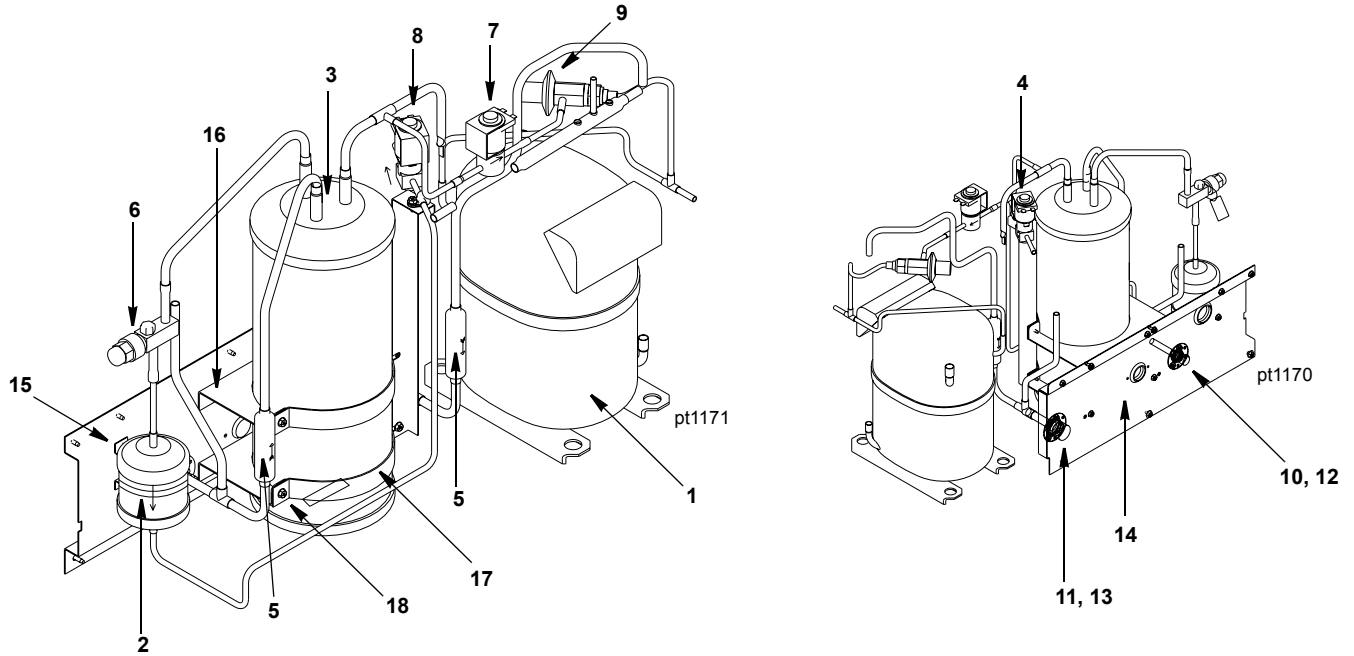

### DESCRIPTION

	<b>PART NO.</b>
1 Compressor (Refer to COMMON PARTS) . . . . .	Page 4
2 Drier . . . . .	† 89-3027-9
3 Receiver . . . . .	† 76-2957-3
4 Safety Soft Plug . . . . .	† 628451-9
5 Magni-Check Valve . . . . .	† 83-7314-9
6 Refrigeration Service Valve . . . . .	† 83-7316-9
a. Cap for Refrigeration Service Valve . . . . .	56-5075-3
7 <b>Harvest Pressure Regulating Solenoid (HPR) Valve</b>	
a. HPR Valve Including 208/230V 50/60 Hz Electrical Coil (Danfoss) . . . . .	† 76-3006-1
b. HPR Valve 208-230V/50-60 Hz Coil Only Danfoss . . . . .	20-0177-3
c. HPR Valve 208-230V/50-60 Hz Coil Only Alco . . . . .	† 24-0448-3
8 <b>Liquid Line Solenoid (LLS) Valve</b>	
a. LLS Valve Including 208/230V 50/60 Hz Electrical Coil (Danfoss) . . . . .	† 76-3008-1
b. LLS Valve 208/230V 50/60 Hz Coil Only Danfoss . . . . .	20-0177-3
c. LLS Valve 208/230V 50/60 Hz Coil Only Alco . . . . .	† 24-0448-3
9 Harvest Pressure Regulating Valve (HPR) . . . . .	† 83-6779-3
10 Coupling – Male, 5/8-18 . . . . .	† 83-6034-3
11 Coupling – Male, 1-1/16-12 . . . . .	† 83-6035-3

### Miscellaneous – Brackets, Screws, etc.

12 Coupling Mounting Flange (for 5/8-18) . . . . .	83-6005-3
13 Coupling Mounting Flange (for 1-1/16-12) . . . . .	83-6006-3
14 Back Panel . . . . .	601906-1
15 Drier Support Bracket . . . . .	601737-1
16 Receiver Mounting Bracket . . . . .	600056-1
17 Receiver Mounting Strap . . . . .	630721-4
18 Screw, #10-24 x .50 . . . . .	† 52-0206-9

† Refer to Cross Reference Guide

## Q600 PANELS

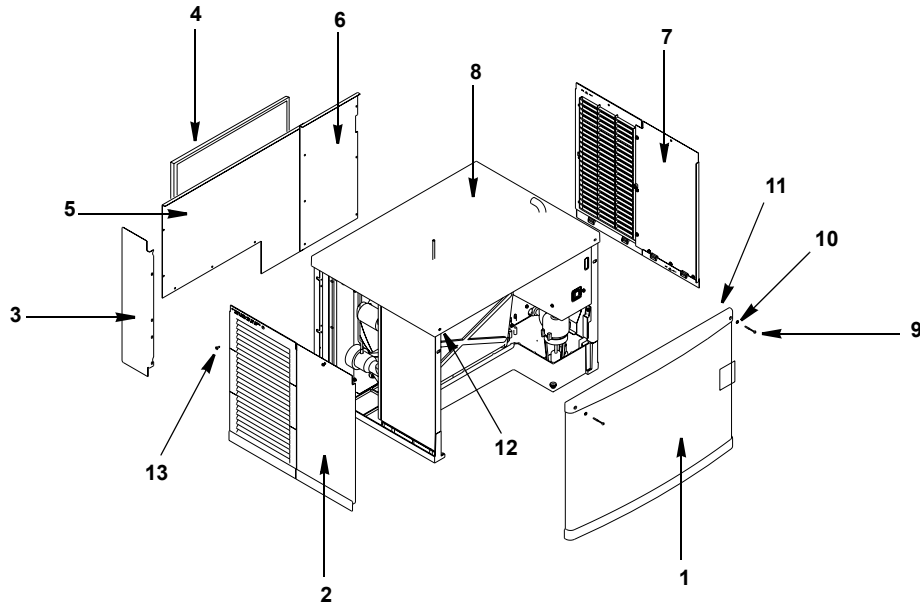

pt1177

### DESCRIPTION

DESCRIPTION	PART NO.
1 Front Panel Assembly . . . . .	76-2853-3
2 Left Side Panel . . . . .	† 76-2830-3
3 Air Baffle . . . . .	602363-1
4 Air Filter . . . . .	40-4018-3
5 Back Panel, Water or Remote . . . . .	601998-1
6 Back Panel, Air . . . . .	602158-1
7 Right Side Panel . . . . .	† 76-2831-3
8 Top Cover . . . . .	43-0331-3

### Miscellaneous – Brackets, Screws, etc.

9 Front Cover Screw . . . . .	† 51-1901-9
10 Front Cover Washer . . . . .	† 55-7338-9
11 Front Cover Screw Retainer . . . . .	† 56-4827-9
12 Speed Nut Assembly to Mount Front Cover . . . . .	† 54-7303-9
13 Screw, #10-24 x .50 Flat . . . . .	† 52-0209-9
14 Extruded Tape (Not shown) . . . . .	† 92-0250-9
15 Front Top Support (Not Shown) . . . . .	† 658041-9

**NOTE:** Items 9, 10, 11 and 12 can be ordered as assembly 76-2898-3.



## JC0895 REMOTE CONDENSER (USED WITH Q600 AND Q800 REMOTE ICE MACHINES)

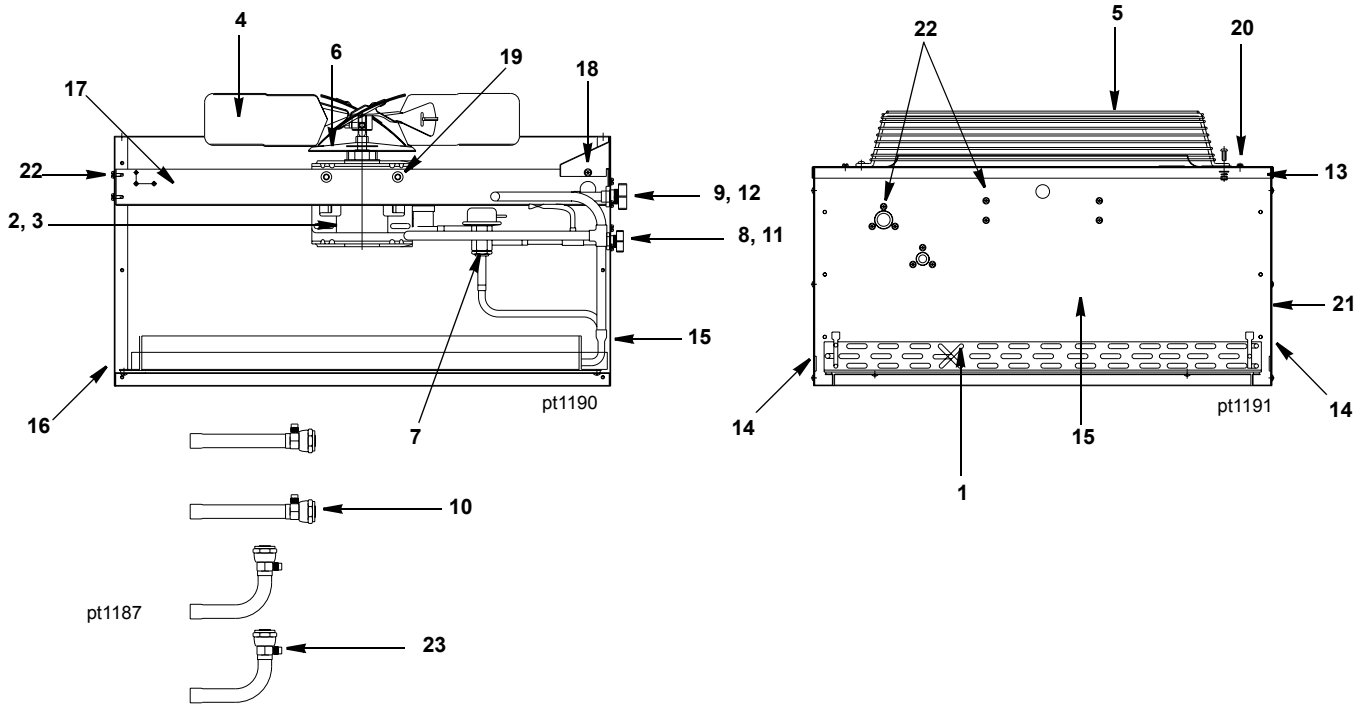

### DESCRIPTION

DESCRIPTION	PART NO.
1 Air Condenser .....	† 88-5062-9
2 Fan Motor (208-230V 50/60 Hz/1 Ph) .....	† 76-2941-3
3 Fan Motor Run Capacitor (Emerson) .....	85-0458-3
3 Fan Motor Run Capacitor (Magnatec) .....	85-0352-3
4 Fan Blade .....	24-1611-3
5 Fan Guard .....	34-0064-3
6 Rain Slinger .....	24-1505-3
7 Head Pressure Control .....	83-6809-3
8 Coupling – Male, 5/8-18 .....	† 83-6034-3
9 Coupling – Male, 1- 1/6-12 .....	† 83-6035-3
10 Female Line Set Coupling Kit (Sold as Finished Goods Sales Kit) .....	Sales K0129

### Miscellaneous – Brackets, Screws, etc.

11 Coupling Mounting Flange (for 5/8-18) .....	83-6005-3
12 Coupling Mounting Flange (for 1-1/16-12) .....	83-6006-3
13 Top Cover .....	† 601775-1
14 Panel – Side .....	† 601774-1
15 Panel – Rear .....	† 601773-1
16 Panel – Front .....	† 601772-1
17 Fan Motor Mounting Bracket .....	† 601768-1
18 Electrical Box Cover .....	† 601776-1
19 <b>Fan Motor Mounting Screw (5/16-18 x 5/8)</b> .....	† 50-3565-9
a. Fan Motor Mounting Flatwasher .....	† 55-7309-9
b. Fan Motor Mounting Lockwasher .....	† 55-7313-9
c. Fan Motor Mounting Hexnut .....	54-2975-9
20 <b>Fan Guard Mounting Screw (1/4-20 x 5/8)</b> .....	† 50-3345-9
a. Fan Guard Mounting Flatwasher .....	† 55-7304-9
b. Fan Guard Mounting Lockwasher .....	† 55-4511-9
c. Fan Guard Mounting Hexnut .....	† 54-2952-9
21 <b>Panel/Condenser Mounting Screw (#8 x 1/2)</b> .....	† 51-2153-9
a. Panel/Condenser Mounting Lockwasher .....	† 55-4459-9
22 Screw (#10-24 x 1/2) .....	† 52-0206-9
23 Valve Cores (used in linesets) .....	76-2684-3
24 Legs (Not shown) .....	† 601769-1

† Refer to Cross Reference Guide

## DC0862 DUAL CIRCUIT REMOTE CONDENSER (USED WITH Q600 AND Q800 REMOTE ICE MACHINES)

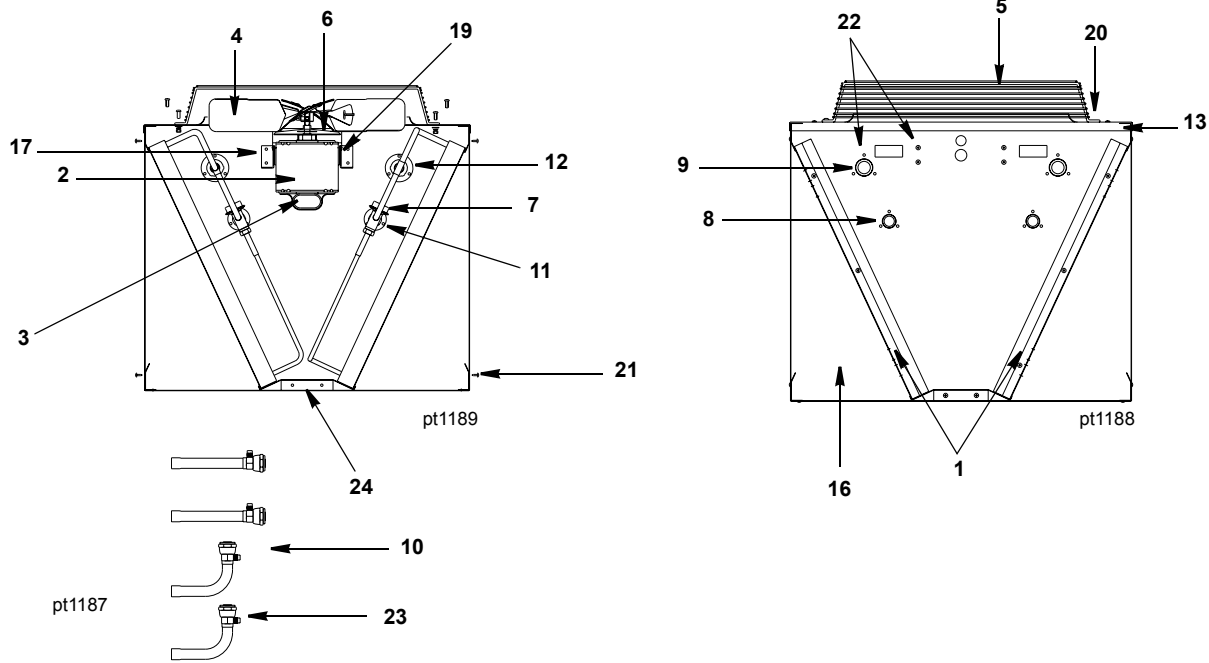

### DESCRIPTION

	<b>PART NO.</b>
1 Air Condenser . . . . .	† 88-5062-9
2 Fan Motor (115V/60 Hz/1 Ph) . . . . .	† 76-2942-3
3 Fan Motor Run Capacitor . . . . .	85-0352-3
4 Fan Blade . . . . .	24-1611-3
5 Fan Guard . . . . .	34-0064-3
6 Rain Slinger . . . . .	24-1505-3
7 Head Pressure Control . . . . .	83-6809-3
8 Coupling – Male, 5/8-18 . . . . .	† 83-6034-3
9 Coupling – Male, 1-1/6-12 . . . . .	† 83-6035-3
10 Female Line Set Coupling Kit (Sold as Finished Goods Sales Kit) . . . . .	Sales K0129

### Miscellaneous – Brackets, Screws, etc.

11 Coupling Mounting Flange (for 5/8-18) . . . . .	83-6005-3
12 Coupling Mounting Flange (for 1-1/16-12) . . . . .	83-6006-3
13 Top Cover . . . . .	601789-1
14 Legs (Not shown) . . . . .	† 601769-1
15 Panel – Rear (Not shown) . . . . .	† 601788-1
16 Panel – Front . . . . .	† 601787-1
17 Fan Motor Mounting Bracket . . . . .	† 601768-1
18 Electrical Box Cover (Not shown) . . . . .	† 601776-1
19 <b>Fan Motor Mounting Screw</b> (5/16-18 x 5/8) . . . . .	† 50-3565-9
a. Fan Motor Mounting Flatwasher . . . . .	† 55-7309-9
b. Fan Motor Mounting Lockwasher . . . . .	† 55-7313-9
c. Fan Motor Mounting Hexnut . . . . .	54-2975-9
20 <b>Fan Guard Mounting Screw</b> (1/4-20 x 5/8) . . . . .	† 50-3345-9
a. Fan Guard Mounting Flatwasher . . . . .	† 55-7304-9
b. Fan Guard Mounting Lockwasher . . . . .	† 55-4511-9
c. Fan Guard Mounting Hexnut . . . . .	† 54-2952-9
21 <b>Panel/Condenser Mounting Screw</b> (#8 x 1/2) . . . . .	† 51-2153-9
a. Panel/Condenser Mounting Lockwasher . . . . .	† 55-4459-9
22 Screw (#10-24 x 1/2) . . . . .	† 52-0206-9
23 Valve Cores (used in linesets) . . . . .	76-2684-3
24 Base Angle . . . . .	601779-1
25 Fan Cycle Kit K00095 (Not shown)	
a. Relay . . . . .	24-0819-3
b. Relay Mounting Bracket . . . . .	600000-1
c. Transformer . . . . .	24-1027-3
d. Electrical Junction . . . . .	25-1501-3

† Refer to Cross Reference Guide