



Ice Machine Parts List for Series S850 Models

SD0852A

SY0854A

SD0853W

SY0855W

SD0892N

SY0894N

SR0850A

JC0895

SR0851W

SR0890N

S850 CONTROL BOX

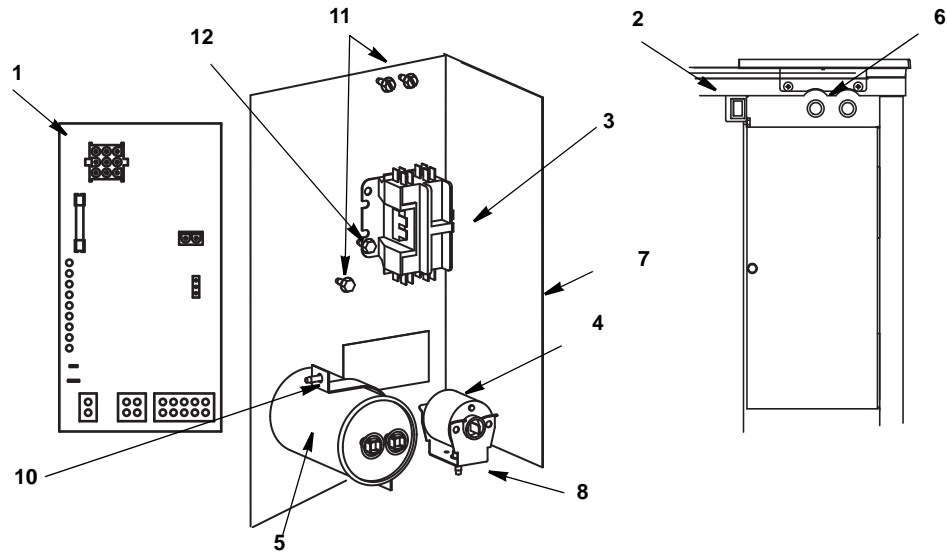

PT1388

1	Control Board (for use with all voltages)	20-0619-9
	a. 7 Amp Fuse – Mounted on Control Board	25-1100-3
2	Toggle Switch Only	20-0793-9
	a. Toggle Switch Wiring Harness	20-0807-9
	b. Toggle Switch Box	40-1163-9
3	Contactor	
	a. 208-230V/60 Hz/1 Ph or 230V/50 Hz/1 Ph	20-0659-9
	b. 208-230V/60 Hz/3 Ph	20-0661-9
4	P.T.C.R. Compressor Starter	85-0499-3
5	Compressor Run Capacitor 208-230V/50/60 Hz/1 Ph)	85-0393-3
6	Refrigeration Service Valve Assembly	83-7326-3
Miscellaneous – Brackets, Screws, etc.		
7	Control Box	76-0214-3
	a. Control Box Cover (Not shown)	76-0215-3
8	P.T.C.R. Compressor Starter Mounting Bracket	85-0501-3
9	Control Board Mounting Supports (Not shown)	43-0225-3
10	Capacitor Mounting Strap	602495-3
11	Screw, #10-24 x .50 Ground	52-0216-9
	a. Star Washer	55-7320-9
12	Screw, #10-24 x .50	52-0206-9
13	Control Box Wiring Harness (Not shown)	
	a. 230/60/1	20-0734-9
	b. 230/60/3	20-0736-9
	c. 230/50/1	20-0735-9

S850 EVAPORATOR COMPARTMENT

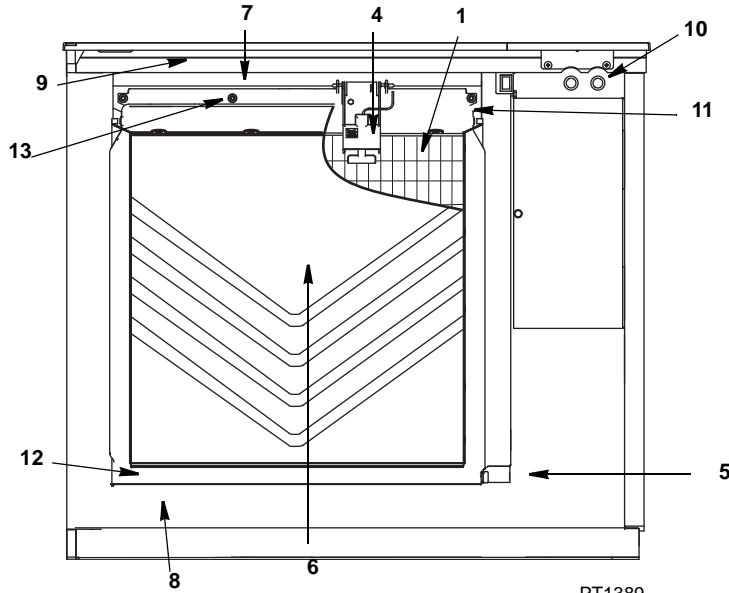

PT1389

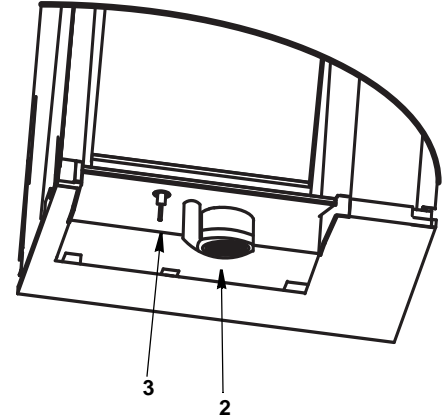

PT1390

DESCRIPTION

	PART NO.
1 Evaporator Assembly	
a. Dice Cube	76-0216-3
b. Half Dice Cube	76-0217-3
c. Regular Cube	76-0218-3
2 Water Pump	
a. 230V/60 Hz 1/3PH	82-5113-9
b. 230/50/1	82-5270-9
3 Water Level Probe	20-0654-9
a. Wire, control box to probe.	20-0798-9
4 Ice Thickness Control Probe	20-0802-9
5 Magnetic Bin Switch	20-0681-9
6 Water Curtain	40-1098-9
7 Water Distribution Assembly	76-0219-3
a. O-Rings (Back of Distribution Assembly)	50-0464-9
8 Water Trough	40-0360-9
9 Evaporator Top Filler Panel	40-0846-9
a. Stainless Steel Clamp	606333-9
b. Clamp Screw.	52-0209-3
10 Access Valve	83-7326-3
11 Evaporator Top Frame Assembly	76-0220-3
12 Water Diverter	76-0221-3
a. Thumbscrew	53-0512-3
Miscellaneous – Brackets, Screws, etc.	
13 Screw, (Water Distribution Tube Mounting) Each	50-0479-9
a. O-Ring.	50-0462-9
14 Screw, #12-16 x .687 (Used to Mount Evaporator) Each	50-0461-9
15 Water Pump Base O-Ring	50-0465-9
16 Water Pump Outlet O-Ring	50-0467-9
17 Vinyl Tubing 0.625 ID (dump valve to drain adapter)	000001382
a. Insulation.	603883-1

S850 REFRIGERATION COMPARTMENT – COMMON PARTS

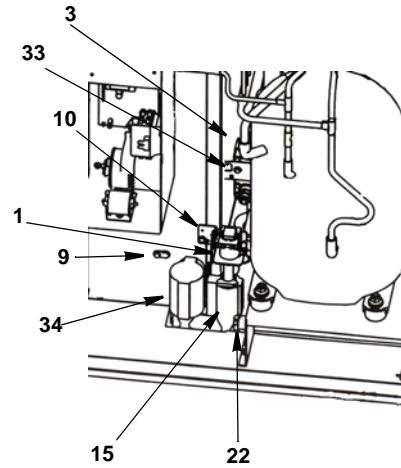
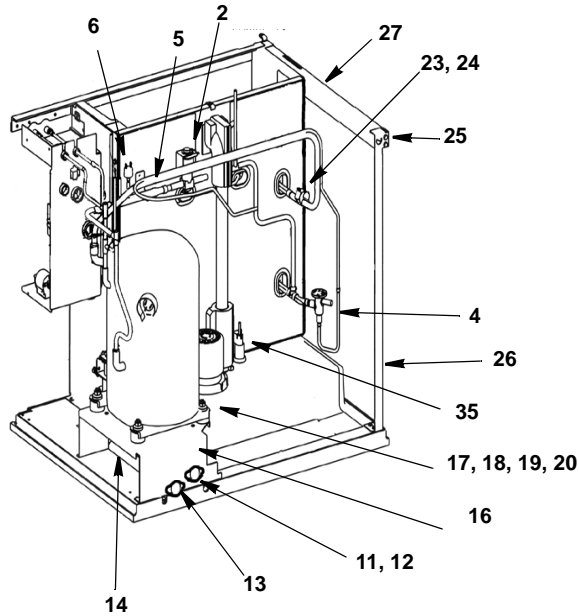

DESCRIPTION

		PART NO.
1	Water Dump Valve	
	a. Dump Valve, 208-230V/50-60 Hz	000001768
	b. Dump Valve Rebuild Kit.	No Longer Available
2	Harvest Valve	
	a. Harvest Valve Including 208/230V 50/60 Hz Electrical Coil	76-3012-1
	b. Harvest Valve 208/230V 50/60 Hz Coil Only Alco.	† 24-0448-3
	c. Harvest Valve 208/230V Coil Only Danfoss	000005157
3	Water Inlet Valve	
	a. Water Inlet Valve Including 208-230V/50/60 Hz Coil.	000000378
4	Expansion Valve	76-0225-3
	a. Expansion Valve Body Insulation Boot	40-0036-3
	b. Expansion Valve Bulb Insulation Boot	40-0720-3
5	Manifold Strainer (in front of hot gas valve)	82-5104-9
6	High Pressure Cut-out (Auto Reset)	20-0124-3
7	Electrical Box on Rear of Ice Machine	
	a. Box	Included in Back Panel Assembly
	b. Terminal Block 3 Pole	20-0614-9
	c. Groundscrew #10-24 x .50	52-0216-9
8	Compressor Compartment Wiring Harness	
	a. Water	20-0732-9
	b. Air	20-0731-9
	c. Remote	20-0733-9
9	Bin Switch	20-0681-9

Miscellaneous – Brackets, Screws, etc.

10	Dump Valve Mounting Bracket	605845-9
11	Water Inlet Valve Wing Adapter	87-0609-3
12	Water Inlet Valve Wing Adapter Plastic Fitting	13-6096-1
13	Water Drain Female Wing Adapter	87-0608-3
14	Water Drain Clear Tubing, .625 ID x 12 inches	44-2038-3
15	Dump Valve Tubing (3.25 inches)	44-2038-3
16	Compressor Mounting Base	606170-9
17	Compressor Mounting Rubber Grommet †	85-0306-9
18	Compressor Mounting Sleeve	85-0394-9
19	Compressor Mounting Bolt	50-0481-9
20	Compressor Mounting Nut	50-0482-9
21	Compressor Wiring Harness (Not Shown)	20-0623-9
22	Clamp, Water Drain	56-5070-9
23	Clamp, Expansion Valve Bulb	56-5052-9
24	Copper Bulb Strap	30-0050-3
25	Screw, #10-24 x .50	52-0206-9
26	Left Corner Post	606865-9
27	Left Top Channel	606864-9
28	Right Corner Post (Not Shown)	606177-9
29	Right Top Channel (Not Shown)	606257-9
30	Insulated Tube (vinyl tubing from distribution tube to water pump & dump valve)	000003406
	a. Clamp .859/.989 ID	56-5060-3
	b. Clamp .799/.899 ID	56-5070-3
31	Water Inlet Valve Tubing (Not Shown)	40-1043-9
32	Connector (Water inlet valve)	13-6098-9
33	Water Inlet Valve Bracket	605845-9
34	Check Valve Replacement (includes water diverter, vinyl tubing & insulation)	000002473
35	Holder, Water Level Probe	20-0655-9
	a. Screw (mounts Water Level Probe Holder)	52-0209-9

† Refer to Cross Reference Guide

S850 REFRIGERATION COMPARTMENT – AIR-COOLED

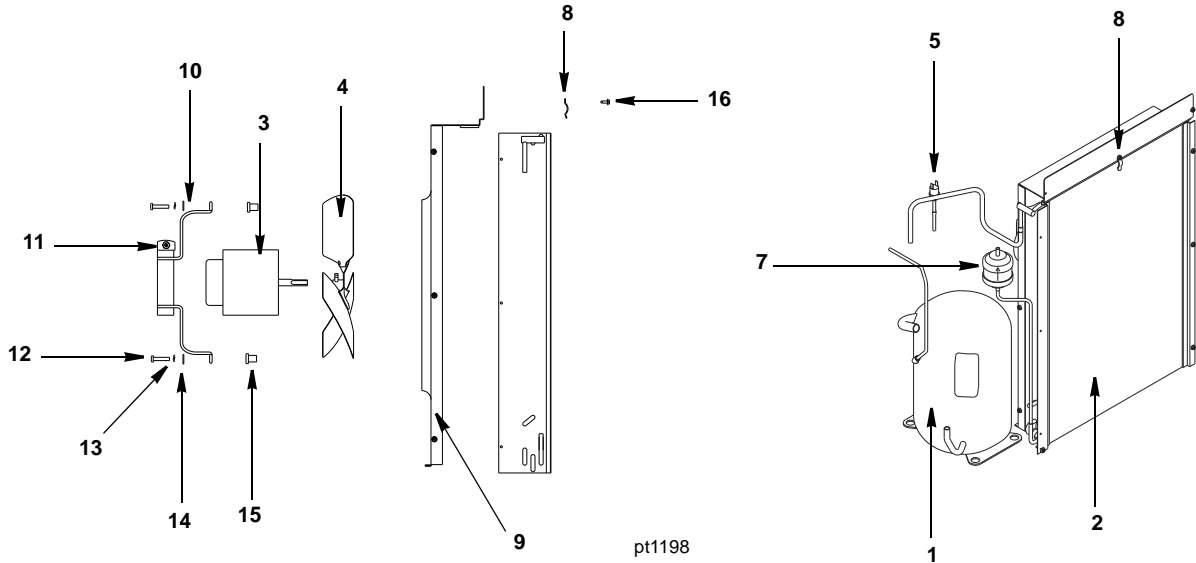

DESCRIPTION

	PART NO.
1 Compressor (After Serial Number 110683282)	
a. 208-230V/60 Hz/1 Ph	000001736
b. 208-230V/60 Hz/3 Ph	000001737
c. 230V/50 Hz/1 Ph	000001738
1 Compressor (Before Serial Number 110683282)	
a. 208-230V/60 Hz/1 Ph	76-0222-3
b. 208-230V/60 Hz/3 Ph	76-0223-3
c. 230V/50 Hz/1 Ph	76-0224-3
2 Air Condenser	82-5239-9
3 Fan Motor (208-230V/60 Hz or 230V/50 Hz)	76-2672-3
4 Fan Blade	24-1612-3
5 Fan Cycling Control	† 20-0126-3
6 Air Filter (Not shown)	30-0555-9
7 Drier	89-3025-9
Miscellaneous – Brackets, Screws, etc.	
8 Air Filter Clip	† 56-5069-9
9 Fan Shroud	605811-9
10 Fan Motor Mounting Bracket	34-0616-3
11 Fan Motor Mounting Screw	† 50-3358-9
a. Fan Motor Mounting Lockwasher	† 55-4510-9
b. Fan Motor Mounting Hexnut	† 54-2952-9
12 Fan Bracket Mounting Screw	50-3238-9
13 Fan Bracket Mounting Lockwasher	† 55-4510-9
14 Fan Bracket Mounting Flatwasher	† 55-7305-9
15 Fan Bracket Mounting Rubber Wellnut	† 54-2955-9
16 Screw, #10-24 x .50	† 52-0206-9

† Refer to Cross Reference Guide

S850 REFRIGERATION COMPARTMENT – WATER-COOLED

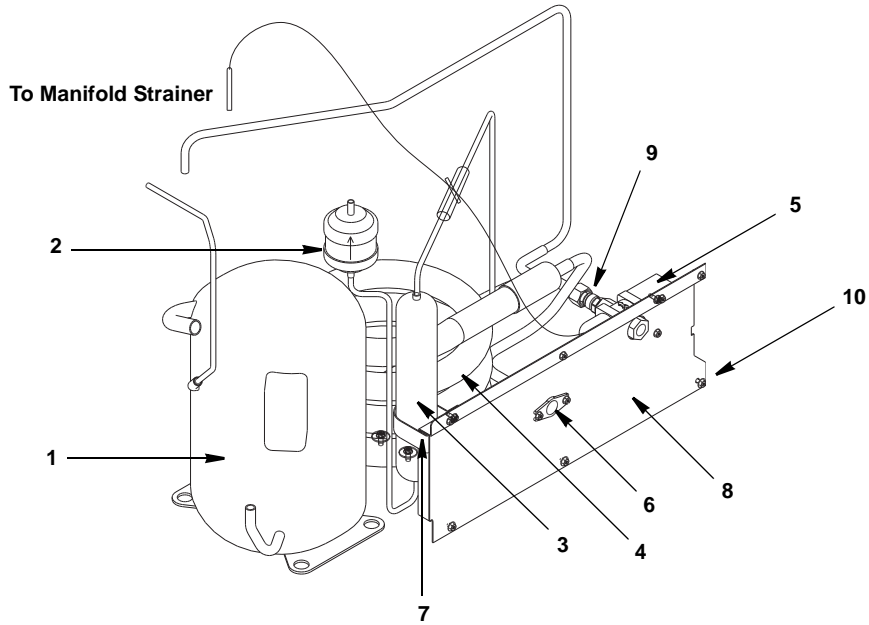

pt1200

DESCRIPTION

DESCRIPTION	PART NO.
1 Compressor (After Serial Number 110683282)	
a. 208-230V/60 Hz/1 Ph	000001736
b. 208-230V/60 Hz/3 Ph	000001737
c. 230V/50 Hz/1 Ph	000001738
1 Compressor (Before Serial Number 110683282)	
a. 208-230V/60 Hz/1 Ph	76-0222-3
b. 208-230V/60 Hz/3 Ph	76-0223-3
c. 230V/50 Hz/1 Ph	76-0224-3
2 Drier	89-3025-9
3 Receiver	89-0012-3
4 Water-Cooled Condenser	† 000001507
5 Water Regulating Valve	83-7206-9
6 Water Drain Female Wing Adapter	87-0608-3
Miscellaneous – Brackets, Screws, etc.	
7 Receiver Strap	600054-1
8 Back Panel	606173-9
9 Elbow .50 MF x .375 MPT	50-0224-9
10 Screw, #10-24 x .50	52-0206-3
11 Washer	55-7341-9
12 Base, Water Condenser/Receiver	605865-9

† Refer to Cross Reference Guide

S850 REFRIGERATION COMPARTMENT – REMOTE

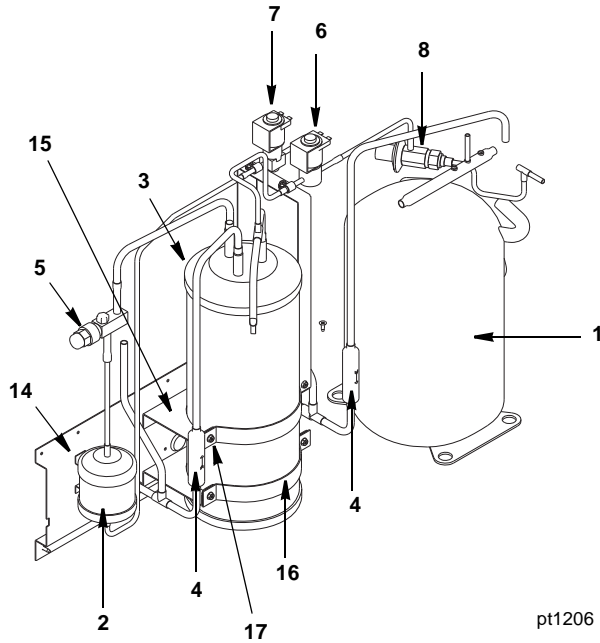

pt1206

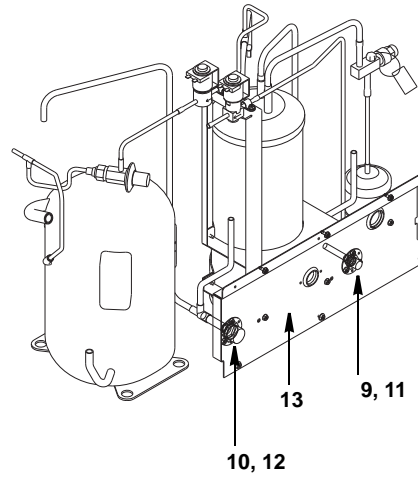

pt1207

DESCRIPTION

	PART NO.
1 Compressor (After Serial Number 110682385)	
a. 208-230V/60 Hz/1 Ph	000001736
b. 208-230V/60 Hz/3 Ph	000001737
c. 230V/50 Hz/1 Ph	000001738
1 Compressor (Before Serial Number 110682385)	
a. 208-230V/60 Hz/1 Ph	76-0222-3
b. 208-230V/60 Hz/3 Ph	76-0223-3
c. 230V/50 Hz/1 Ph	76-0224-3
2 Drier	89-3027-9
3 Receiver	89-0000-9
4 Magni-Check Valve	† 83-7314-9
5 Refrigeration Service Valve	† 83-7316-9
a. Cap for Refrigeration Service Valve	56-5075-9
6 Harvest Pressure Regulating Solenoid (HPR) Valve	
a. HPR Valve Including 208/230V 50/60 Hz Electrical Coil (Danfoss)	† 76-3006-1
b. HPR Valve 208/230V 50/60 Hz Coil Only Danfoss	000005157
7 Liquid Line Solenoid (LLS) Valve	
a. LLS Valve Including 208/230V 50/60 Hz Electrical Coil (Danfoss)	† 76-3008-1
b. LLS Valve 208/230V 50/60 Hz Coil Only Danfoss	000005157
8 Harvest Pressure Regulating Valve (HPR)	† 83-6779-3
9 Coupling – Male, 5/8-18	† 83-6034-3
10 Coupling – Male, 1-1/6-12	† 83-6035-3
Miscellaneous – Brackets, Screws, etc.	
11 Coupling Mounting Flange for 5/8-18	83-6005-3
12 Coupling Mounting Flange for 1-1/16-12	83-6006-3
13 Back Panel	606173-9
14 Drier Support Bracket	56-5061-9
15 Receiver Mounting Bracket	600056-1
16 Receiver Mounting Strap	630721-4
17 Screw, #10-24 x .50	† 52-0206-9
18 Base (Receiver Mounting)	605865-9

† Refer to Cross Reference Guide

S850 PANELS

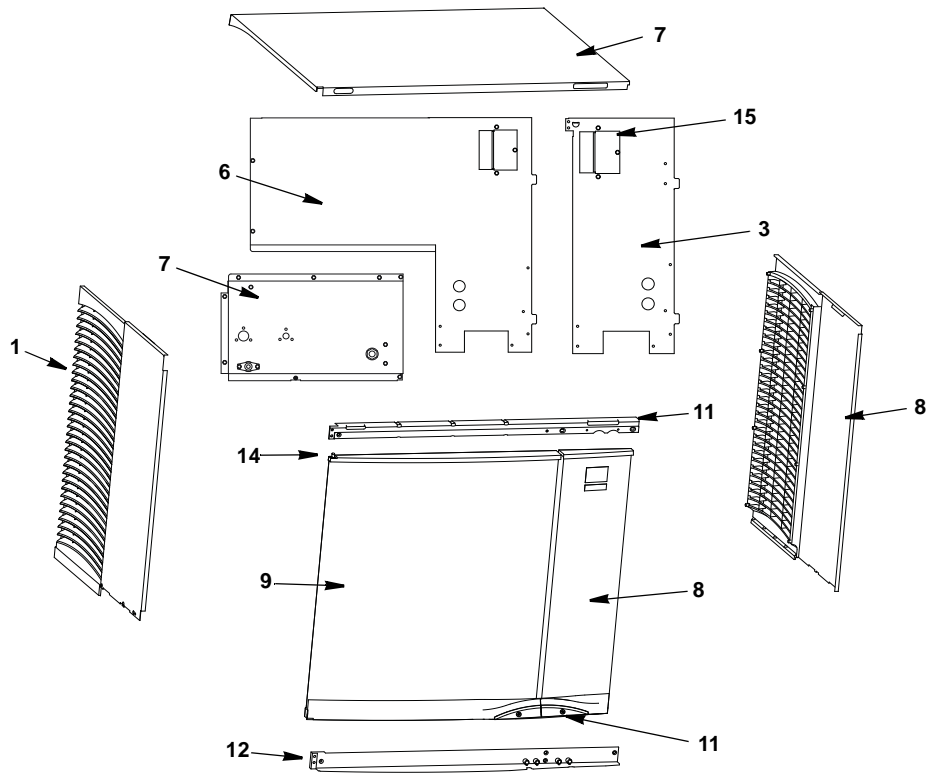

DESCRIPTION

- 1 Left Side Panel
- 2 Right Side Panel

Air-Cooled Back Panels)

- 3 Back Panel with Electrical Connection Box, Air-cooled Models
- 4 Air Filter (Not Shown)
- 5 Air Baffle (Not Shown)

Water-Cooled & Remote Air-Cooled Back Panels)

- 6 Back Panel with Electrical Connection Box
- 7 Back Coupling Panel, Water Connections

Aluminum Front Top Support on machine (replace all)

- 8 Top Cover
- 9 Right Door
- 10 Left Door
- 11 Front Top Support
- Mounting Screw Left Side 8-32 x 1
- Mounting Screw Right Side 10-24 x .50

Plastic Front Top Support on machine (replace as needed)

- 7 Top Cover
- 8 Right Door
- 9 Left Door
- 10 Front Top Support
- Mounting Screw Left Side 8-32 x 1
- Mounting Screw Right Side 10-24 x .50

Miscellaneous – Brackets, Screws, etc.

- 11 Right/Left Door Screw
- 12 Bottom Door Frame
- a. Mounting Screw Left Side 8-32 x 1 PHIL
- b. Mounting Screw Right Side 10/24 x .50 PHIL
- 13 Door Catch Bracket (RHD)
- a. Mounting Screw 8-32 x .50 Phil
- 14 Left Door Pivot Leaf Hinge (Top or Bottom)
- a. Mounting Screw 8-32 x 1 PHIL
- 15 Electrical Connection Box Cover
- 16 Sachet Holder (inside left door)
- a. Screws

PART NO.

- 606055-9
- 606054-9
- 606169-9
- 30-0555-9
- 605971-9
- 605864-9
- 606173-9
- 40-1548-3
- 607122-1
- 607121-1
- 000000295
- 50-0537-9
- 50-0509-9
- 40-1548-3
- 607122-1
- 607121-1
- 000000295
- 50-0537-9
- 50-0509-9
- 50-0489-9
- 76-0226-3
- 50-0537-9
- 52-0209-9
- 606236-9
- 50-2624-9
- 30-0557-9
- 50-0537-9
- Included in Back Panel Assembly
- 40-0459-9
- 50-0479-9

JC0895 REMOTE CONDENSER

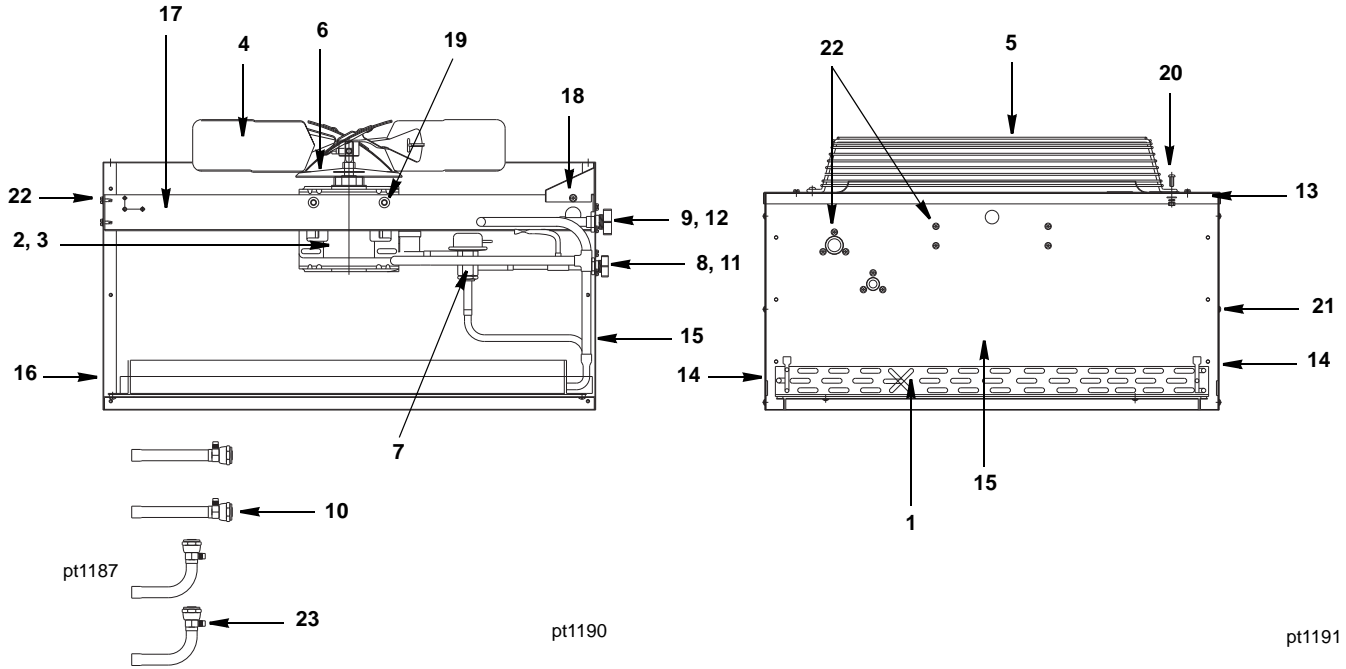

DESCRIPTION

	PART NO.
1 Air Condenser	† 88-5062-9
2 Fan Motor (208-230V 50/60 Hz/1 Ph)	† 76-2941-3
3 Fan Motor Run Capacitor (Emerson)	85-0458-3
3 Fan Motor Run Capacitor (Magnatec)	No Longer Available
4 Fan Blade	24-1611-3
5 Fan Guard	34-0064-3
6 Rain Slinger	24-1505-3
7 Head Pressure Control	83-6809-3
8 Coupling – Male, 5/8-18	† 83-6034-3
9 Coupling – Male, 1-1/6-12	† 83-6035-3
10 Female Line Set Coupling Kit (Sold as Finished Goods Sales Kit)	Sales K0129

Miscellaneous – Brackets, Screws, etc.

11 Coupling Mounting Flange (for 5/8-18)	83-6005-3
12 Coupling Mounting Flange (for 1-1/16-12)	83-6006-3
13 Top Cover	† 601775-1
14 Panel – Side	† 601774-1
15 Panel – Rear	† 601773-1
16 Panel – Front	† 601772-1
17 Fan Motor Mounting Bracket	† 601768-1
18 Electrical Box Cover	† 601776-1
19 Fan Motor Mounting Screw (5/16-18 x 5/8)	† 50-3565-9
a. Fan Motor Mounting Flatwasher	† 55-7309-9
b. Fan Motor Mounting Lockwasher	† 55-7313-9
c. Fan Motor Mounting Hexnut	54-2975-9
20 Fan Guard Mounting Screw (1/4-20 x 5/8)	† 50-3345-9
a. Fan Guard Mounting Flatwasher	† 55-7304-9
b. Fan Guard Mounting Lockwasher	† 55-4511-9
c. Fan Guard Mounting Hexnut	† 54-2952-9
21 Panel/Condenser Mounting Screw (#8 x 1/2)	† 51-2153-9
a. Panel/Condenser Mounting Lockwasher	† 55-4459-9
22 Screw (#10-24 x 1/2)	† 52-0206-9
23 Valve Cores (used in linesets)	76-2684-3
24 Legs (Not shown)	† 601769-1

† Refer to Cross Reference Guide